

# EASY

INSTALLATION INSTRUCTIONS  
QUARTER POINT CLAMPING

NEXT LEVEL  
MOUNTING

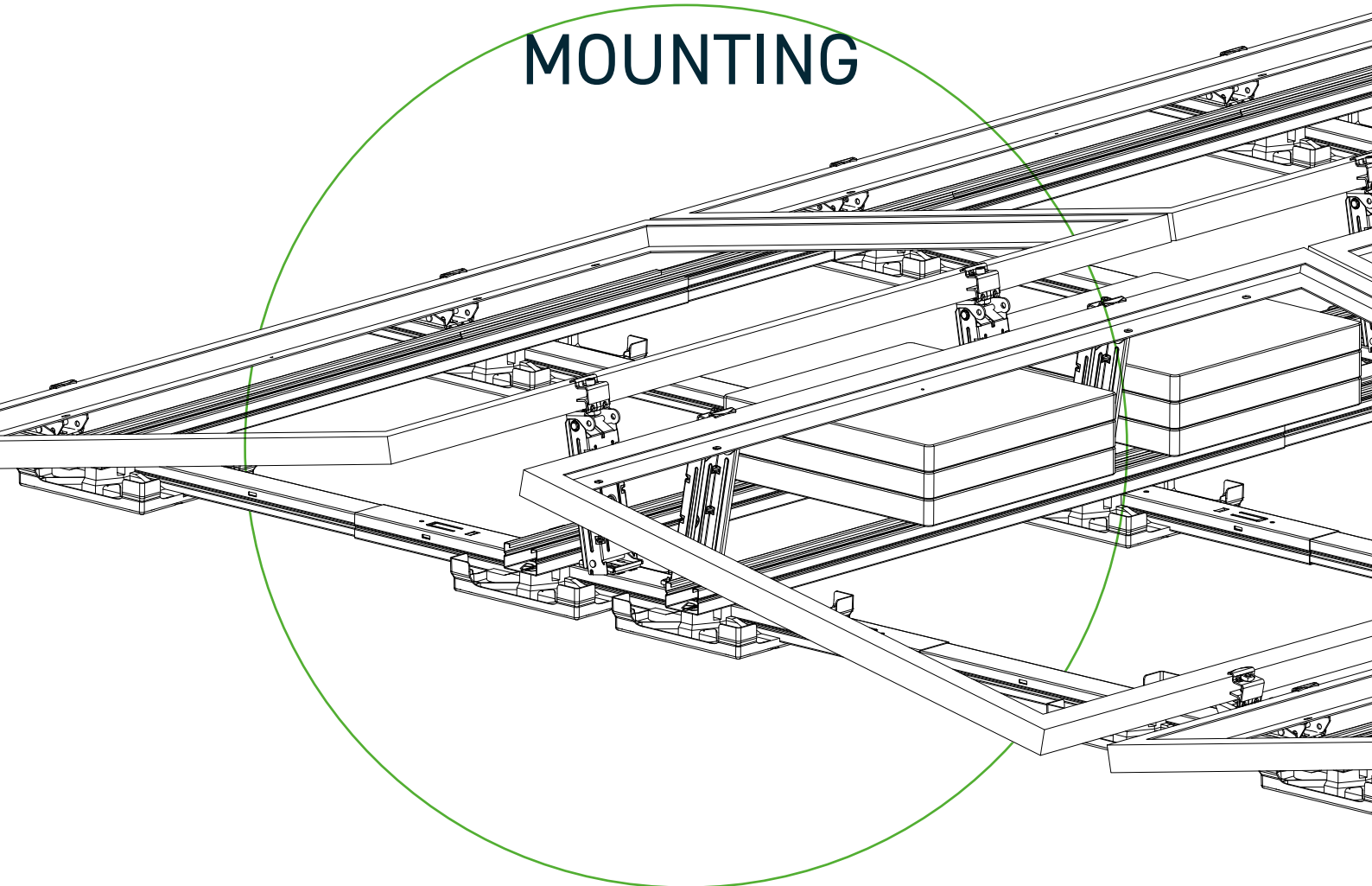

SCOTT  NORGE

# Contents

## EASY QUARTER POINT CLAMPING

General safety instructions	3
General system instructions	4
Installation instructions and maintenance	8
Required tools	9
Basic components	10
Component types	10
Installation	12
Optional components	23
Component types	23
Installation	26
Final examination	37
Warranty and product liability	38



INTERACTIVE INSTALLATION  
INSTRUCTIONS

Click to select page

# General safety instructions



---

Please note that our general safety instructions must be followed.

---

## Installation by specialists only

Scott photovoltaic substructures may only be installed and brought into operation by specialists. Such persons must be able to ensure the proper and professional installation of our products based on their professional qualifications, acquired, for example, as a result of their training or professional experience.

### Before starting installation:

#### 1. Check the structural requirements of the roof and the building:

Before installing the Scott photovoltaic substructure, it is imperative that the customer checks whether the roof and building structure permits the safe installation and operation of the photovoltaic system. This must be checked on site by a qualified person, e.g. a structural engineer, before installation. The information in the project report is based solely on planning assumptions that do not necessarily correspond to the conditions on site. The structural requirements must therefore be clarified by the customer in advance of installation. To do this, obtain confirmation from a specialist and do not start installation without such a document.

#### 2. Compliance with building and accident prevention regulations:

National and local building regulations, standards and environmental protection regulations must be strictly observed.

Occupational safety and accident prevention regulations as well as the regulations of professional associations must be observed.

In particular, it should be noted:

- Safety clothing must be worn (especially hard hat, work shoes and gloves).
- For roof work, the regulations for work on roofs must be observed (e.g. use of guardrails, scaffolding with safety gear from an eaves height of 3 m, etc.).
- Two people must be present during the entire installation process to ensure prompt assistance in the event of an accident.

#### 3. Check installation instructions for updates:

Scott installation systems are subject to continuous further development. Installation procedures can change as a result. It is therefore essential that you check the installation instructions for updates before installation. They can be found at <https://Scott.solutions/downloads/>. We will also be happy to send you the current version of the installation instructions on request.

During the entire installation process, it must be ensured that a copy of the installation instructions is available to each person carrying out the installation.

#### 4. The installation instructions of the module manufacturers must also be observed.

5. Equipotential bonding between the individual system parts must be carried out in accordance with the relevant country-specific regulations.

---

Scott accepts no liability for damage resulting from non-compliance with the general safety instructions.

---

# General system instructions

---

## a. Basic information about planning with Scott PLAN

---

### What is the purpose of Scott PLAN?

Scott PLAN is used to plan the substructures on roofs marketed by Scott based on the data entered by the user and the planning assumptions based on this data, which are stored in Scott PLAN.

### Who can use Scott PLAN to make plans?

#### **Expertise required for planning with Scott PLAN**

The proper and correct use of Scott PLAN requires expertise and experience not only in the field of substructures for photovoltaic systems, but also in the building industry regarding the roofs on which the complete system is to be used by the end customer.

### How does Scott PLAN make plans?

#### 1. Data input by the user as the basis for planning

The starting point and basis for planning with Scott PLAN is always exclusively the project data entered by the user. Scott does not check the accuracy of these data. Instead, the user is solely responsible for the correct recording and entry of data in Scott PLAN.

Attention: If the user does not record and/or enter the data correctly, this will have an impact on the planning. Changes can result in deviating material quantities and deviating structural requirements, among other things. This can lead to damage to life and limb as well as financial losses, for which Scott accepts no liability.

#### 2. Planning assumptions in Scott PLAN

Scott PLAN processes the data entered by the user and makes use of certain planning assumptions. These planning assumptions are themselves derived from technical regulations on which Scott PLAN's calculations are based.

You can find out which planning assumptions the specific planning is based on in the project report.

Scott PLAN takes into account the Eurocodes, i.e. the Europe-wide standardised rules for design in the construction industry, including the national annexes, as well as national building regulations.

Scott strives to ensure that the Eurocodes taken into account are kept current by taking into account any updates. However, we would like to point out that after new rules have been published, a certain amount of time is always required to implement them in the software; for this reason the user is not entitled to corresponding updates and is always responsible for observing the latest version of the rules and regulations on which the programme is based.

The rules and regulations are applied on the basis of the specified location. The user is responsible for checking the correctness of the planning assumptions.

Attention: If the user does not check the planning assumptions for correctness, this will have an impact on the planning. Changes can result in deviating material quantities and deviating structural requirements, among other things. This can lead to damage to life and limb as well as financial losses, for which Scott accepts no liability.

#### 3. What is the purpose of the project report?

What does "What's important is what's on the roof" mean? Scott PLAN creates a project report based on the user's input. But this plan report cannot and should not replace professional planning based on the specific conditions on site.

The project report is therefore not the end of your project planning, but the beginning.

The only appropriate professional approach is the following, which is the sole responsibility of the user:

First step: Before ordering the photovoltaic substructure and especially before installing it on the roof, the user must check the data, planning assumptions and results in the project report for correctness and plausibility.

Second step: ("What's important is what's on the roof") It is imperative that the user also checks the project report against the specific conditions on the roof. In our experience, project-specific features have to be taken into account for every roof, which usually only become apparent on site on the roof.

If users themselves do not have the necessary expertise to review the project report, they must call in a specialist to do so.

If these mandatory verification steps result in changes compared to the project report, a new planning with the changed data must be carried out in Scott PLAN.

Attention: If the user does not verify the data and/or does not verify them correctly against the actual conditions, this will have an impact on the planning. Changes can result in deviating material quantities and deviating structural requirements, among other things. This can lead to damage to life and limb as well as financial losses, for which Scott accepts no liability.

4. What other technical requirements do customers always have to take into account and check independently?

**a. Technical requirements for the roof and its components**

Scott PLAN assumes that the roof and its components are suitable for the installation of a photovoltaic system and that the client has had this verified by an expert prior to planning.

Scott PLAN does not guarantee the compatibility of the Scott photovoltaic substructure with the roof in terms of roof

covering, roof substructure and roof construction. Users must ensure compatibility themselves.

Before installation, users must ensure that the functional layers of the roof structure (e.g. waterproofing layer, thermal insulation layer) are suitable and designed for the installation of photovoltaic systems. In particular, users must ensure that the thermal insulation layer remains functional despite the additional load caused by the installation of the photovoltaic system (substructure and solar modules).

Tip: Obtain approval from the manufacturer of the individual components and verify the manufacturer's specifications with the conditions on site on the roof.

Users must check the suitability, load-bearing capacity and functionality of the entire roof structure for the installation of the photovoltaic system as a whole.

A structural engineer must be consulted to check the load-bearing capacity. Under no circumstances does Scott PLAN replace this review.

Attention: If the user does not check the compatibility of the photovoltaic substructure with the roof and/or does not check it correctly, this will have an impact on the planning. Changes can result in deviating material quantities and deviating structural requirements, among other things. This can lead to damage to life and limb as well as financial losses, for which Scott accepts no liability.

**b. Structural requirements**

Scott PLAN does not take into account the structural requirements of the building on whose roof the photovoltaic system is to be installed.

The building and roof structures must therefore be checked professionally by users on their own responsibility before installation.

A structural engineer must be consulted for this. Under no circumstances does Scott PLAN replace this review.

Attention: If the user does not check the building structure and/or does not check it correctly, this will have an impact on the planning. Changes can lead to deviating material quantities and deviating structural requirements, among other things. This can lead to damage to life and limb as well as financial losses, for which Scott accepts no liability.

### **c. Photovoltaic modules**

Scott PLAN makes it possible to plan with a wide range of photovoltaic modules. However, due to the large number of photovoltaic modules available on the market, not all modules are stored in the database. Modules not included will be added to the database upon separate request based on the module manufacturer's data specification sheet.

Scott does not guarantee that the module data is current. The parameters dimensions and weight in particular must be verified by the customer before planning.

Scott PLAN only takes into account the dimensions and weight of the modules. Other parameters are not taken into account.

This makes it necessary to check the compatibility of the module with the substructure using the module manufacturer's installation guidelines before installation.

Scott PLAN assumes that the modules may also be installed with clamps on the short module sides. This makes it necessary to check whether the clamping points of the module correspond to the manufacturer's specifications before installation. If the connection points do not match the module manufacturer's specifications, we recommend contacting the module manufacturer for approval of the planning.

This approval can either be generally given within the scope of the module certification or, under certain circumstances, can also be given on a project-specific basis by the module manufacturer.

Attention: If the user does not clarify the compatibility of the substructure with the solar modules, this can lead to

financial losses for which Scott accepts no liability.

### **d. Securing the photovoltaic system against displacement due to thermal expansion (so-called "caterpillar effect")**

On the roof, the photovoltaic system is exposed to constant temperature fluctuations. This can lead to very slow downward movements of the substructure on the roof sealing over the course of the service life of the photovoltaic system, even with a very flat roof pitch. This process is also called "temperature migration" or, more vividly, the "caterpillar effect".

The gradual shifting of the photovoltaic system on the roof can cause damage to the cabling, the roof covering (such as foil, bitumen, gravel, substrate, etc.), the other functional layers and any existing structural components (such as skylights, ventilation systems, drainage systems, chimneys, etc.). In the worst case, the photovoltaic system can gradually slide over the edge of the roof over time.

In order to prevent this, we have decided to give a general recommendation of a connection starting at a roof pitch of 1.0°.

This is based on a recommendation by the German Solar Industry Association – BSW-Solar, entitled: "Positional stability due to thermal expansion ("temperature migration")".

Suitable measures to secure the photovoltaic system against displacement due to thermal expansion include coupling module arrays across the roof ridge or attaching the system to the roof structure at specific points.

With the introduction of the new expansion stage of the EVO 2.1 system with ProPlate and its mechanical fastening to the main ground profiles we are amending our recommendation for connecting the EVO 2.1 system to flat roofs. However, this amended recommendation applies exclusively to the EVO 2.1 system. The connection to the roof must only be made from a gradient of approx. 2 % (roof pitch approx. 1.15 °), provided that the following requirements are met:

- The Scott checklist must be completed in full and taken into account in the planning.
- Compliance with the following maintenance routine by Scott customers:

Maintenance interval	Displacement	Measure
annual maintenance	no displacement	no action required
annual maintenance	up to approx. 2 cm	Special attention should be paid to inspecting this condition during the next maintenance
annual maintenance	2 – 3 cm	Interim inspection after approx. 6 months
Interim inspection (6 months)	further displacement of 1.5 cm or more	subsequent mechanical connection

Attention: Failure to secure the photovoltaic system against displacement due to thermal expansion can lead to damage to life and limb as well as property and financial losses, for which Scott accepts no liability.

# Installation instructions and maintenance

## Installation instructions

Installation should not begin until the construction manager's written instructions have been received.

The components of Scott's installation system are used exclusively for fastening PV modules. Depending on the type of roof on the building and the characteristics of the roof, the components intended for this purpose should be used. The exact item details can be found in the project documents, consisting of the project report and the CAD plan.

When using the installation system, compliance with the installation instructions, safety instructions and system instructions is mandatory.

If the components are used for purposes other than those for which they are intended, if the instructions are not followed or if components that are not part of the system are used, all claims under guarantee, warranty and liability vis-à-vis Scott are invalidated. The user is liable for damage and resulting damage to other components, PV modules or the building, as well as for personal injury.

Before starting the installation, the compatibility between the roof skin and the installation system must be tested and ensured and the roof must be checked for damage of any kind. These are to be recorded in the roof inspection report. Remedial work may be required.

In the case of very uneven roofs or roof sealing, compensatory measures may need to be taken to ensure even load distribution. In order to ensure that the main floor profiles lie flat on the roof skin, the roof surface must be cleaned and impurities such as moss, leaves, dirt, stones, etc. removed before construction begins.

The necessary distances to the edges of the roof specified in the project documents must be observed. The maximum module field size depends on the type of roof. For roofs with substrate or gravel fill, ensure that a sufficiently slip-resistant connection is made.

The surface load must not exceed the residual load-bearing capacity of the building. Care must be taken to ensure that the drainage of rainwater is not impeded. The roof drainage must be included in the system planning.

A check must be made to see whether the lightning protection regulations change as a result of the installation of the PV system and need to be modified. Thermal separation (distance between module fields) must be maintained according to the Scott PLAN project documents.

Attention: If the actual module sizes exceed the module widths given in the table, do not begin installation.

The tightening torques specified in the installation instructions must be strictly observed.

After events such as storms, heavy rain, earth movements, etc., the system must be checked for damage by a specialist. If damage is found during the inspection, it must be repaired immediately. Defective components must be replaced with new components.

## Maintenance

Photovoltaic substructures are not maintenance-free. Maintenance, especially the correct positioning of the ballast stones and the building protection mats or ProPlates, must be carried out annually and documented in a maintenance protocol. Furthermore, all components of the Scott installation system must be checked at regular intervals and documented accordingly. In our maintenance protocol we recommend annual maintenance.

The recommendations on the maintenance routines of the EVO 2.1 system due to thermal expansion must be observed.

After unusually strong wind events, we recommend maintenance immediately after the strong wind event.

Attention: Failure to maintain the system can lead to damage to life and limb as well as financial losses, for which Scott accepts no liability.



# Required tools

1 Tape measure

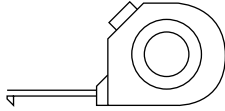

2 Chalk line

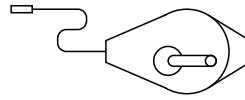

3 Torque wrench  
with attachment  
Hexagon socket  
SW 6 mm

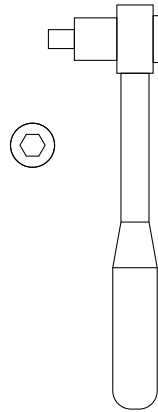

4 Spacing template  
(optional tool)





Attention! Some components are available in different lengths and versions.  
The exact item details can be found in the project documents.

## Component types

### A Swift Rail

1.0529 - S350 GD ZM310

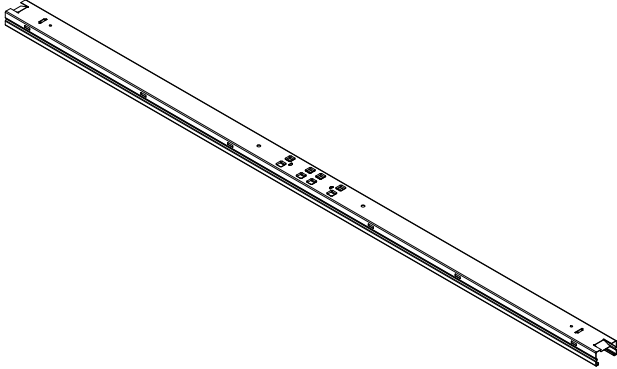

### E Pivot Single

1.0531 - S550 GD ZM310  
1.4301 - S235

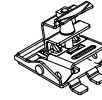

### B Swift Rail Short

1.0529 - S350 GD ZM310

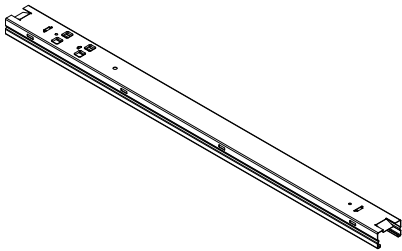

### F EasyPlate

PE-HD

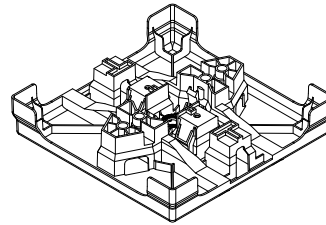

### C Swift Connector

1.0529 - S350 GD ZM310

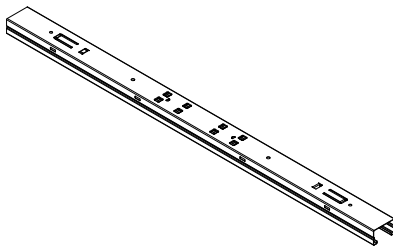

### G Ballast stone with the standard dimensions 40×40×4 cm (not included in delivery)

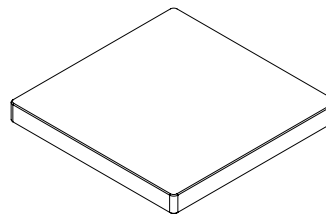

### D Summit Single

1.0529 - S350 GD ZM310  
1.0531 - S550 GD ZM310  
1.4301 - S235

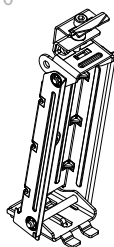

### H Row Connector

1.0529 - S350 GD ZM310

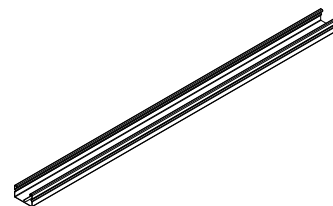



Attention! Some components are available in different lengths and versions.  
The exact item details can be found in the project documents.

# Component types

## | Row Link

1.0529 - S350 GD ZM310

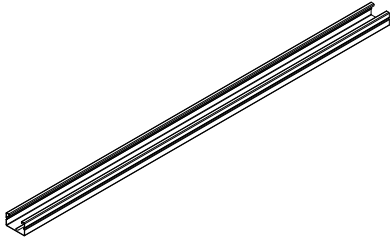

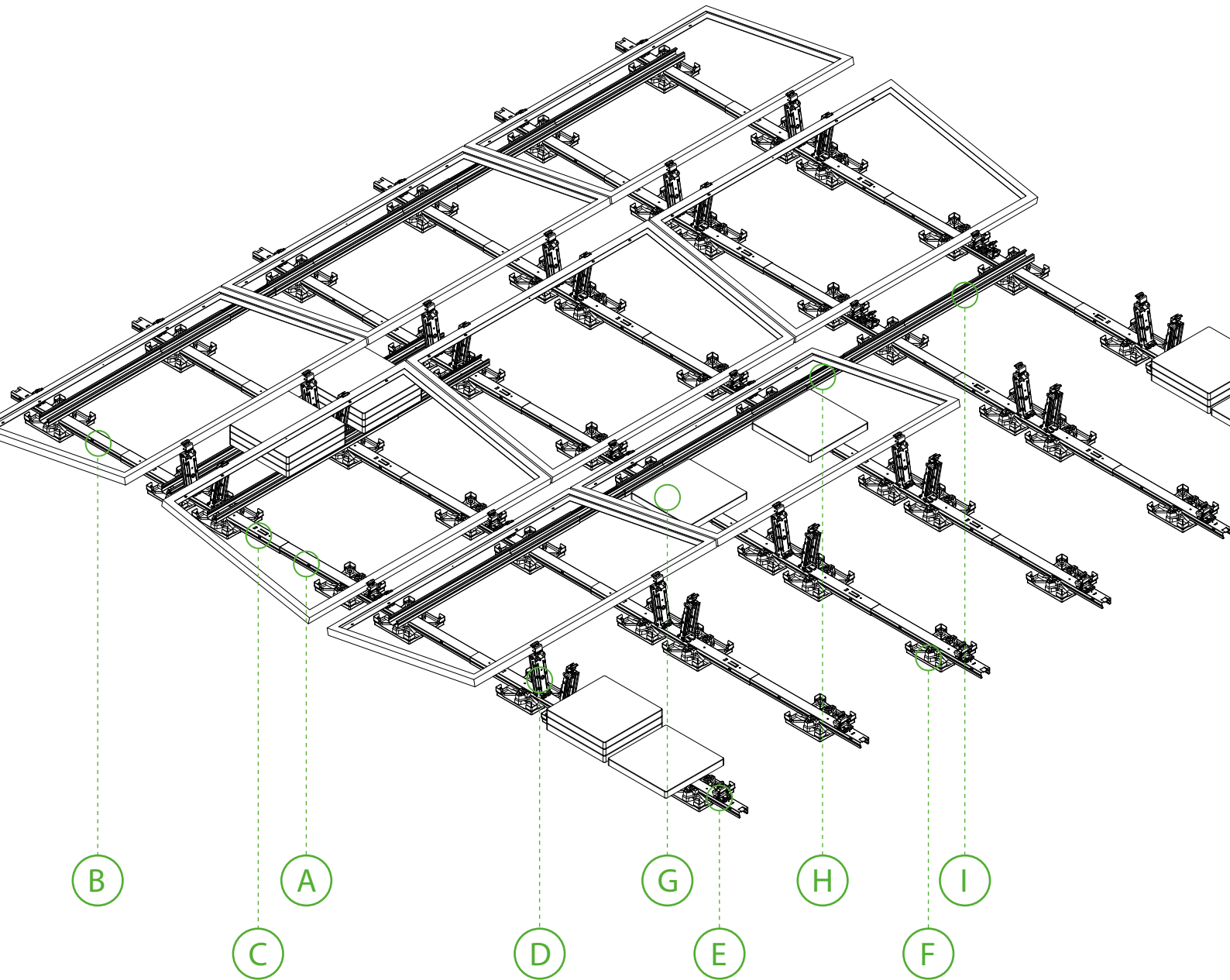

A Swift Rail

B Swift Rail Short

C Swift Connector

D Summit Single

E Pivot Single

F EasyPlate

G Standard ballast stone

H Row Connector

I Row Link

Swift Connection = Connection of Swift Rail and Swift Connector

Row Connection = Row Connector/Link to connection of Swift Connection rows

# 1

Lay out Swift Rail Short **B**, Swift Connector **C** and Swift Rail **A** and connect them together.

Slide the Swift Rail **A** into the Swift Connector **C** profile until you hear a click. Two Swift Rails must be mounted for each Swift Connector. At the beginning and end of a complete string, a Swift Rail Short **B** must be pushed onto the Swift Connector **C**.

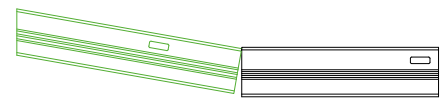
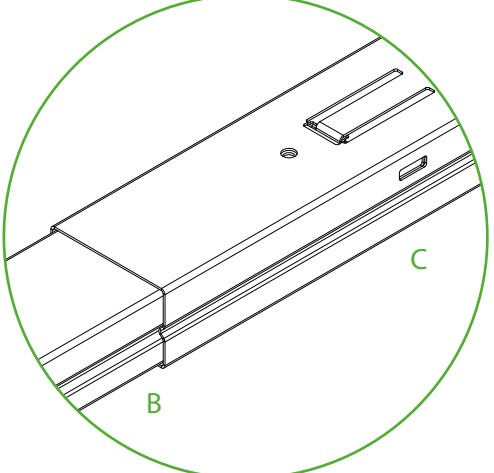
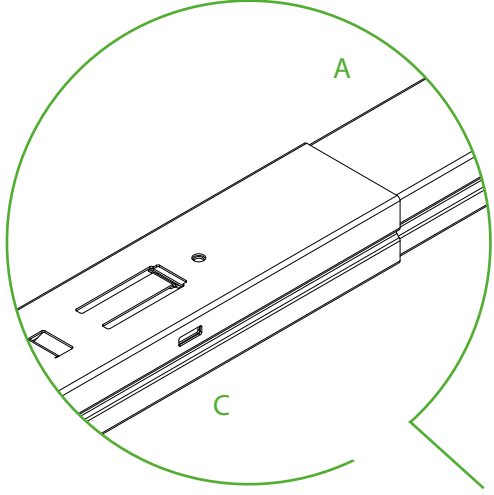
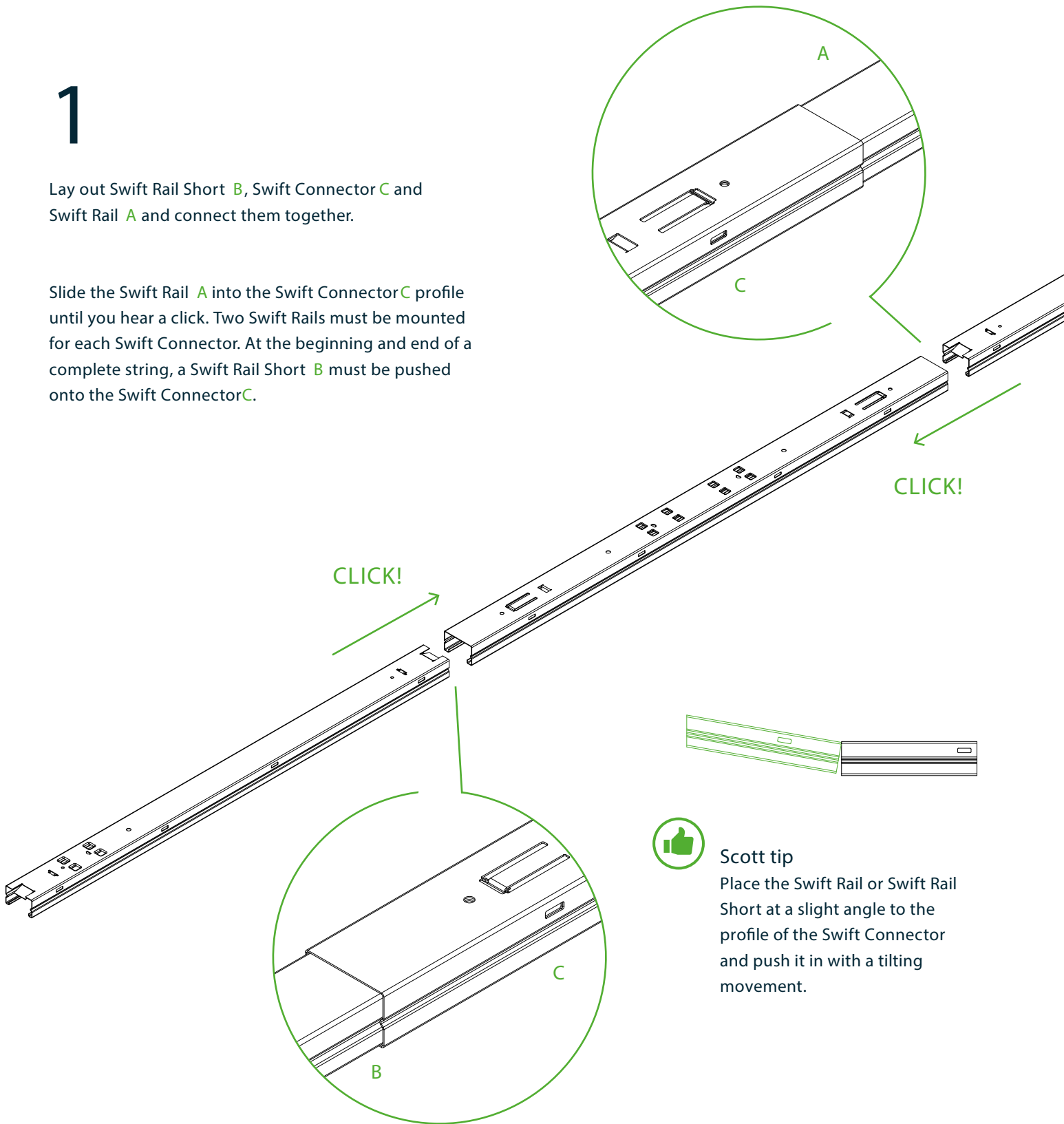

### Scott tip

Place the Swift Rail or Swift Rail Short at a slight angle to the profile of the Swift Connector and push it in with a tilting movement.



### Attention!

Check the snap-lock joint for strength and to ensure it fits perfectly.

CORRECT!

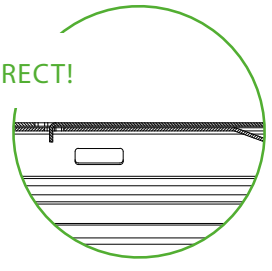

WRONG!

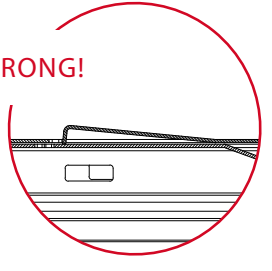

# 2

Install the EasyPlates **F**.

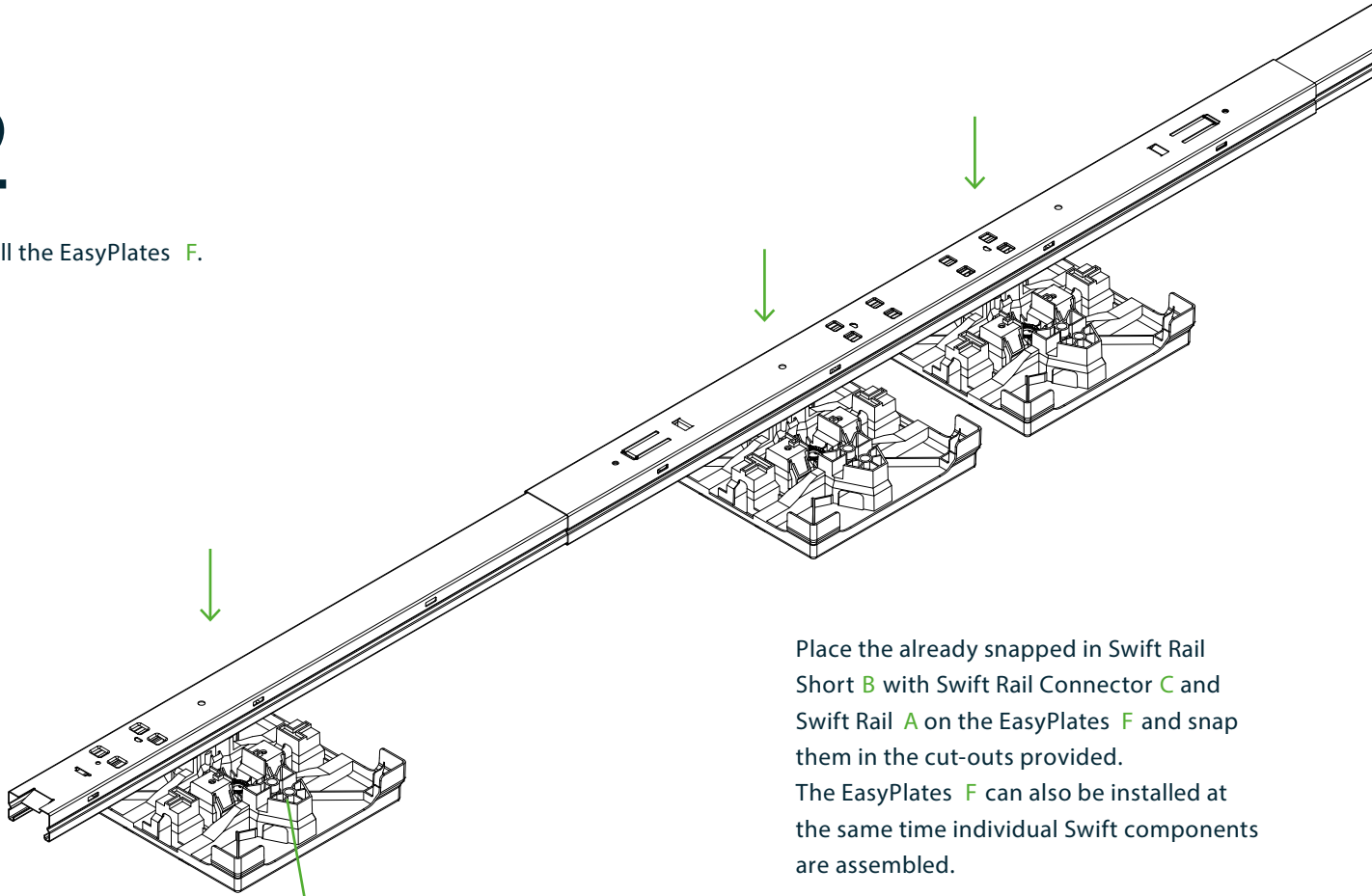

Place the already snapped in Swift Rail Short **B** with Swift Rail Connector **C** and Swift Rail **A** on the EasyPlates **F** and snap them in the cut-outs provided. The EasyPlates **F** can also be installed at the same time individual Swift components are assembled.

Consult the current project report for the exact installation of the EasyPlates.

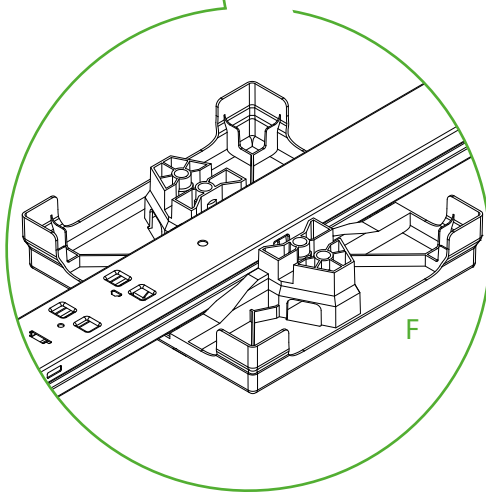

 **Attention!** Ensure that the locking lug is appropriately locked to the Swift Rail, Swift Rail Short or Swift Connector.

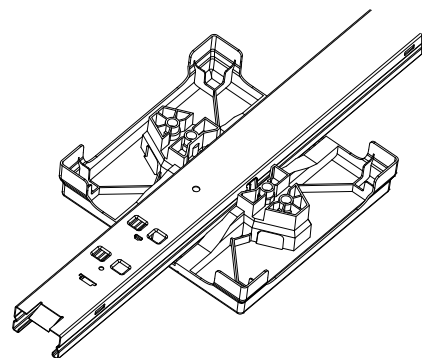
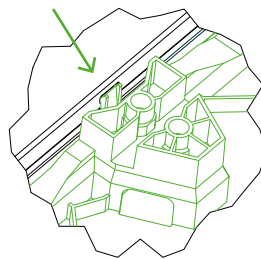
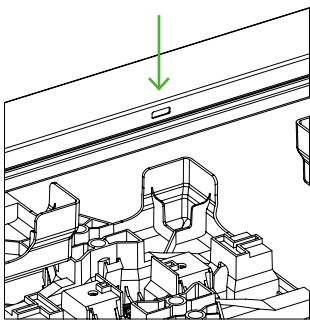

# 3

Put on the Summit Single **D** and Pivot Single **E** and lock them in place.

Press the Summit Single **D** vertically into the recesses of the Swift Connector **C** with the locking lugs pointing away from the centre of the rail and push it towards the edge of the rail until you hear a click.

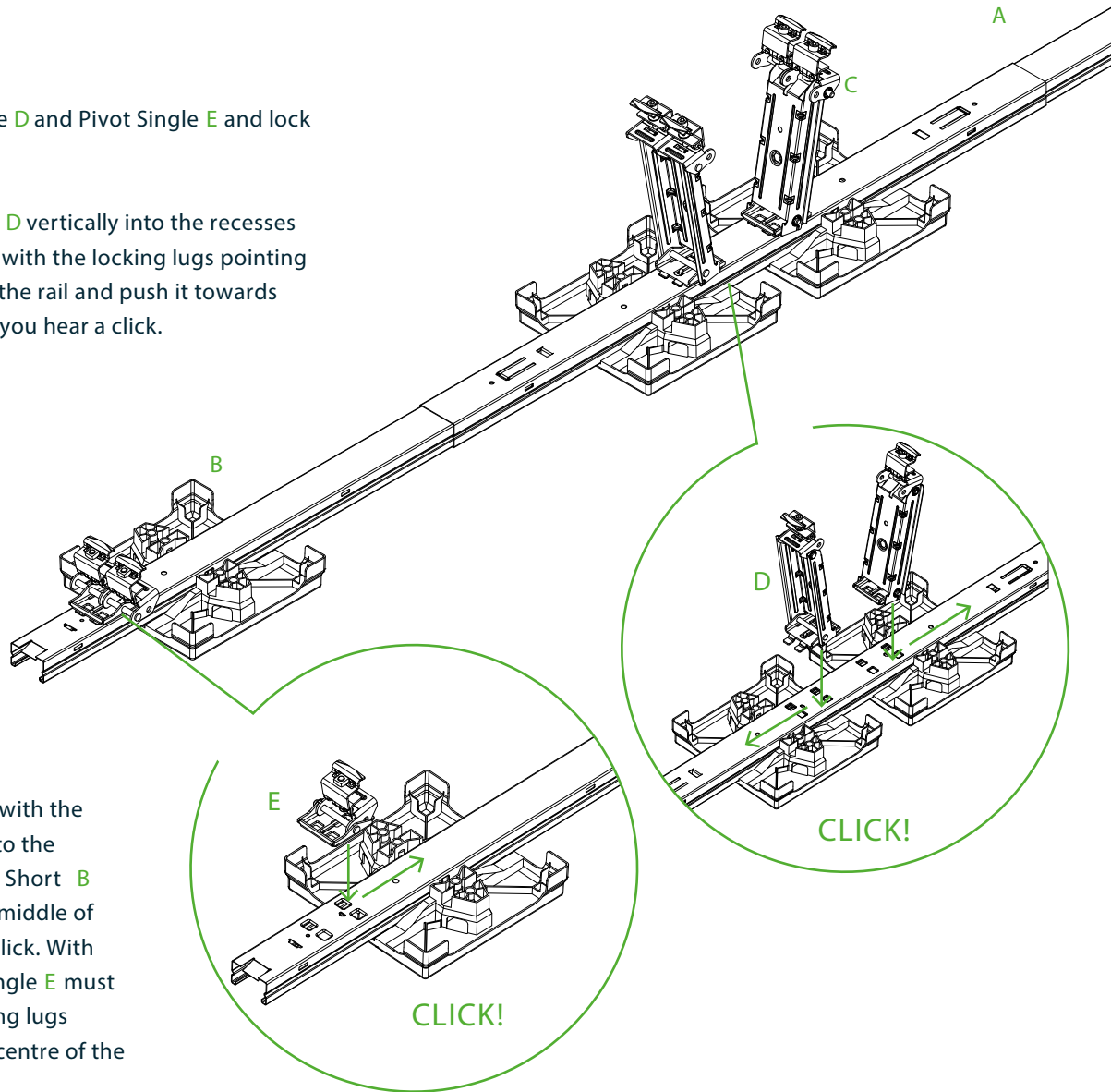

Press the Pivot Single **E** with the locking lugs vertically into the recesses of the Swift Rail Short **B** and push it towards the middle of the rail until you hear a click. With Swift Rail **A**, the Pivot Single **E** must be placed with the locking lugs pointing away from the centre of the rail and locked in place.

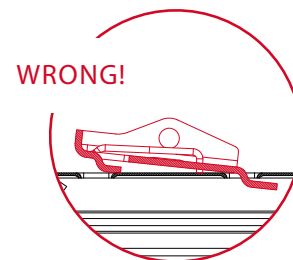
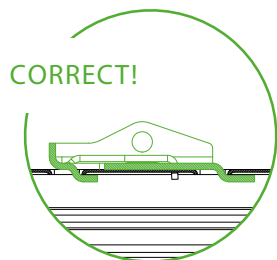
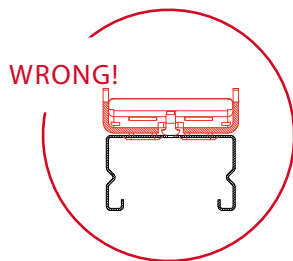
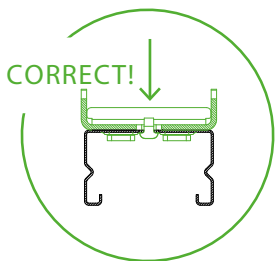

### Attention!

Check the snap-lock joint to ensure it fits perfectly. When assembling, ensure that all 4 locking tabs are inserted into the recess provided and that the hammer head engages in the corresponding T-recess. Apply light pressure to the hammer head to ensure that it assumes its final position.

# 4

Slide Row Link **I** into Row Connector **H**, place on EasyPlate and mount.

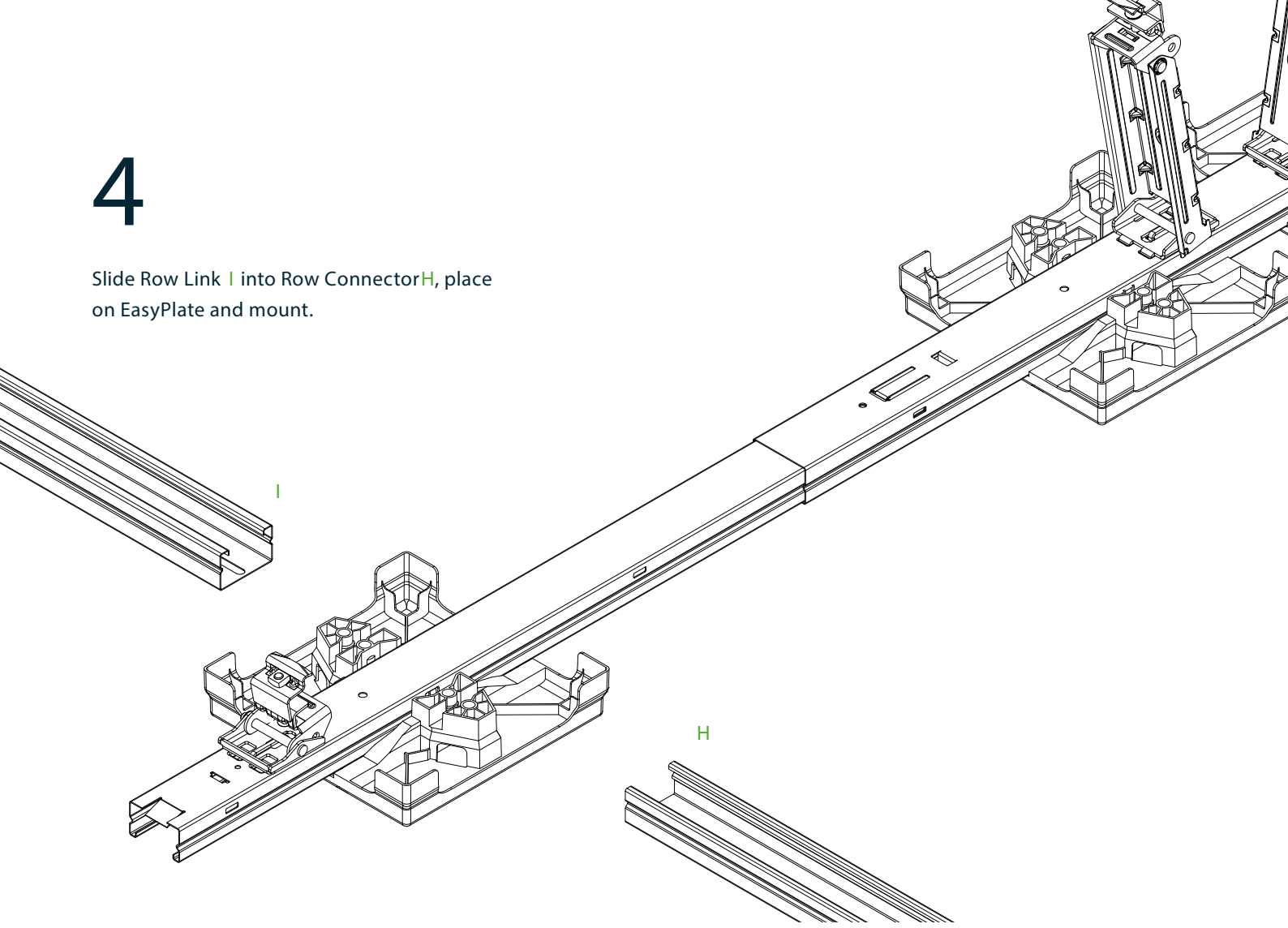

## 4.1

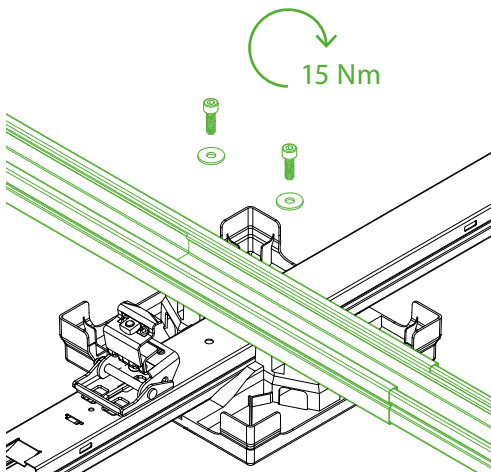

## 4.2

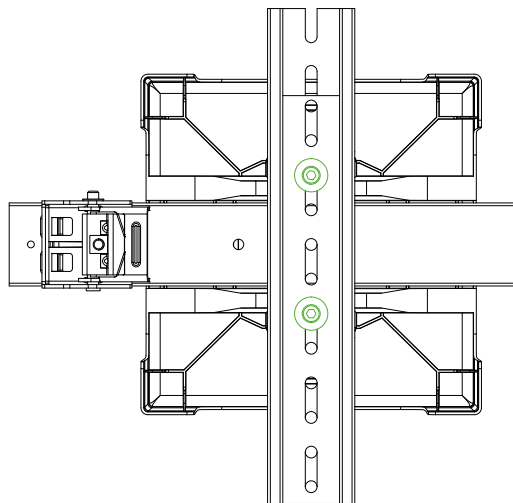

Row Connector Edge **H** and Row Link Edge **I** must be mounted at the specified locations in accordance with the project report.



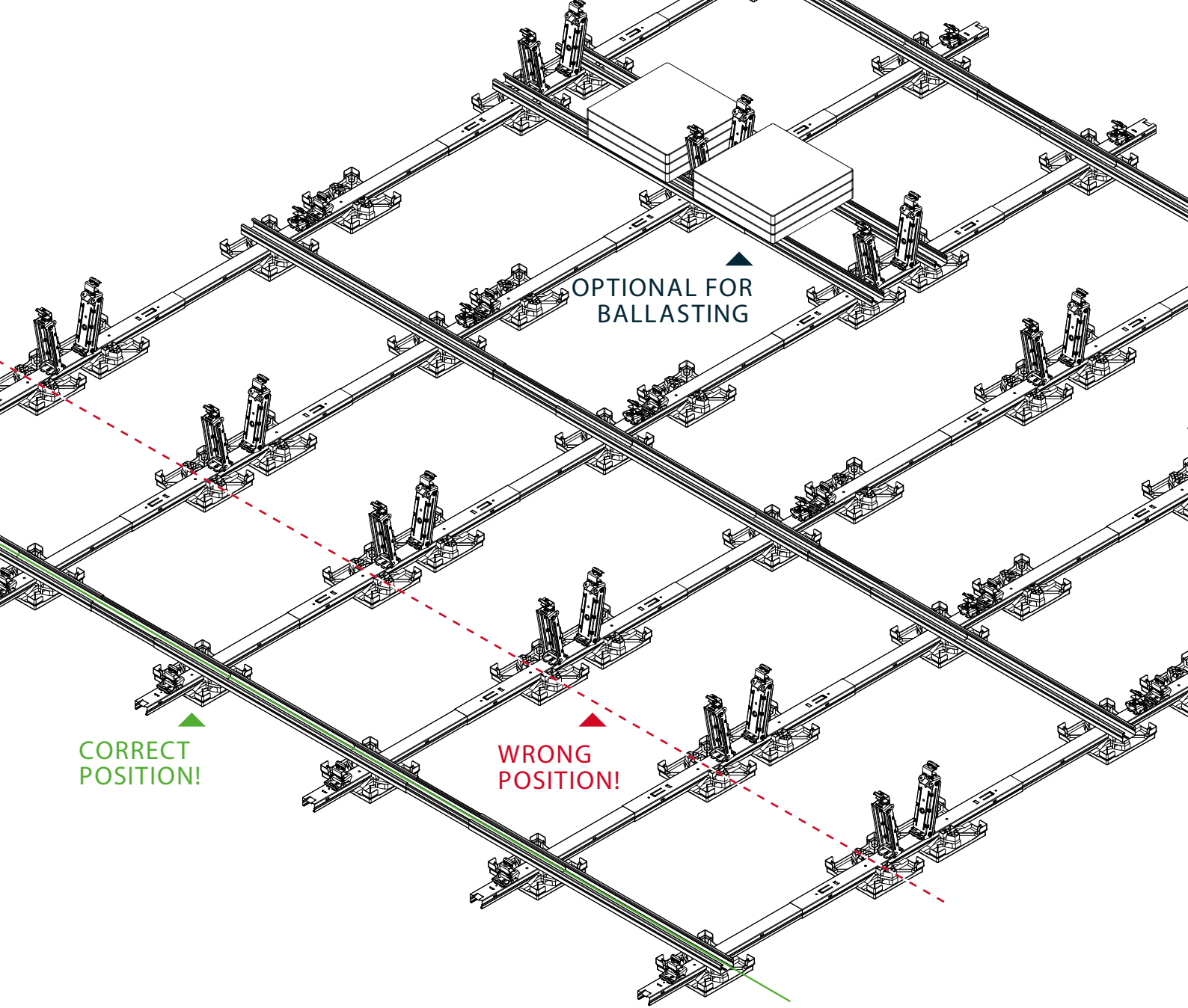

#### NOTE

Please always refer to the current project documents for the exact location / position of the Row Connector H and Row Link I.

Row Connector H and Row Link I must always be mounted once per double module on a pivot and at the end of a system. Ensure that the installation is always carried out on the same side of the single module unit.

# 5

Options for ballasting using the example of a ballast stone **G** (40x40x4).

## Example 1: Placement on the rail

When positioning the ballast stones on the Swift Rail **A**, Swift Rail Short **B** or Swift Connector **C**, the EasyPlates **F** must be placed under the ballast stones **G** at the intended locations.

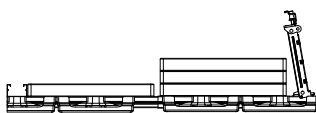
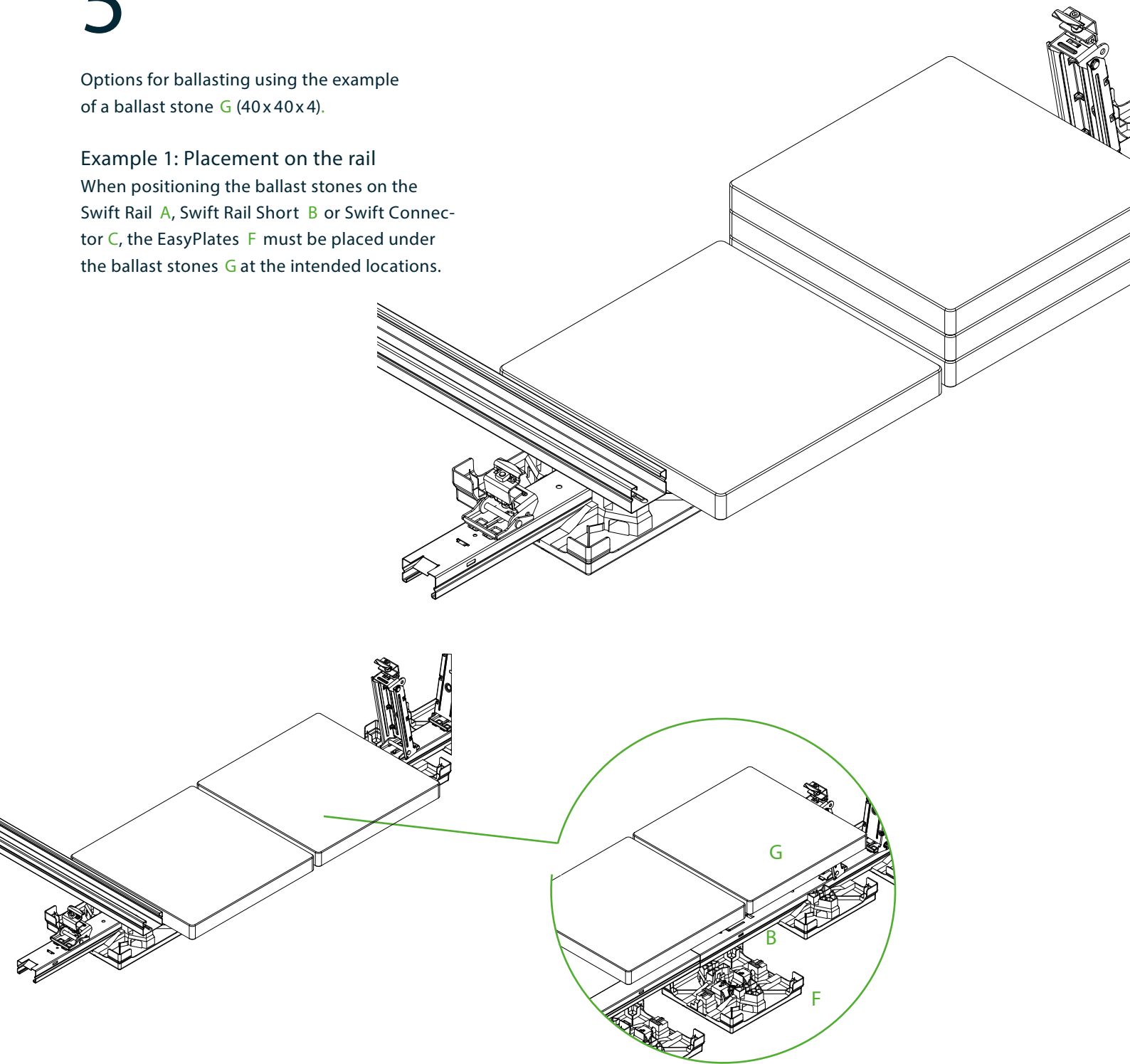

### Attention!

Make sure that at least one complete EasyPlate is placed under one ballast stone.

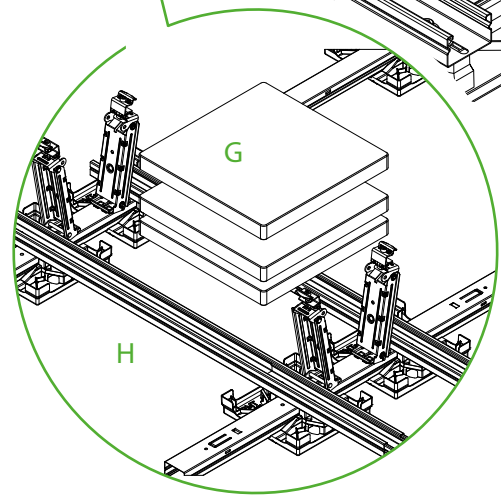
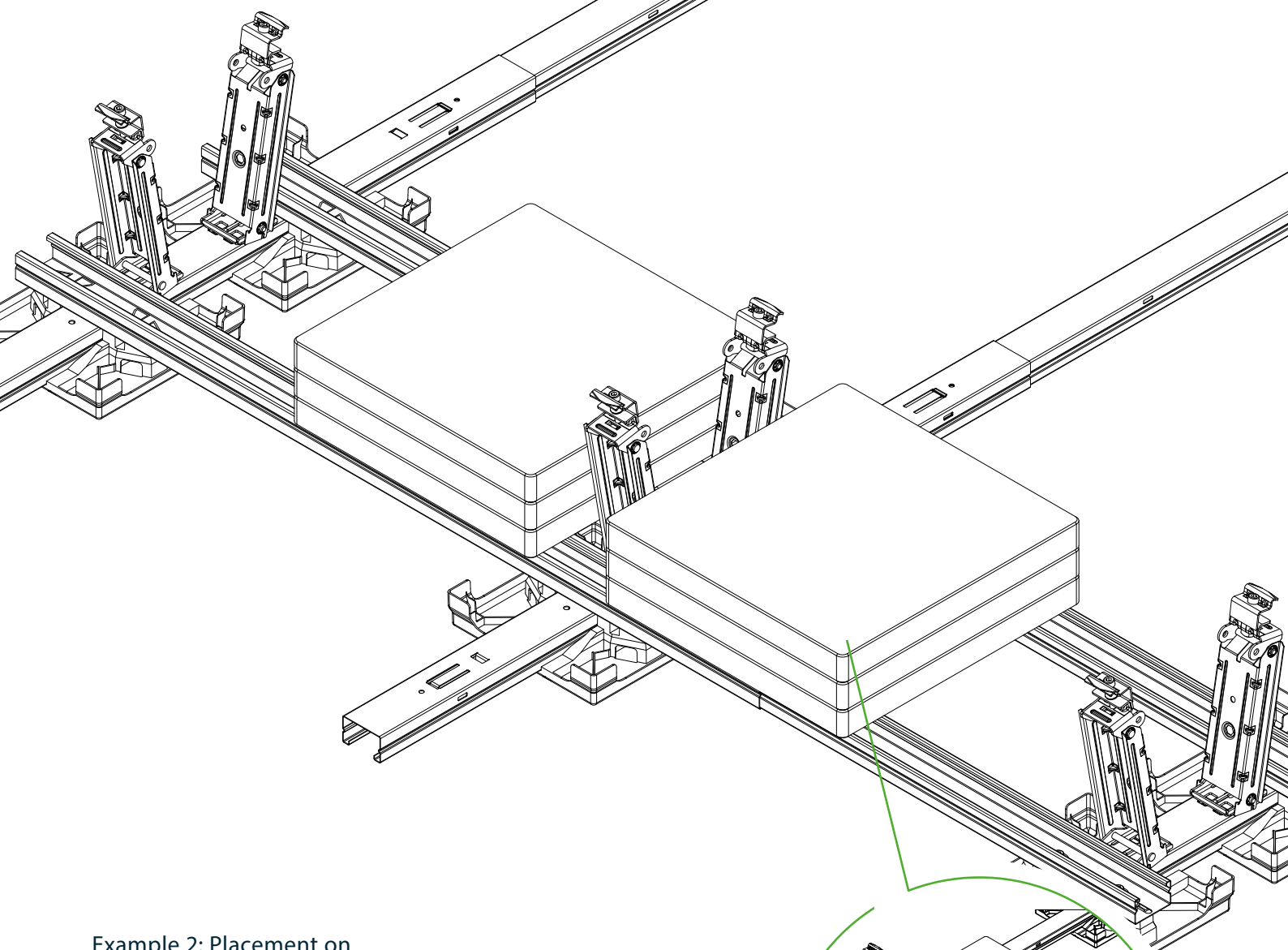

### Example 2: Placement on Row Connector / Row Link

With this placement variant, Row Connector **H** and Row Link **I** are additionally mounted within the system on which the ballast stones are placed.



#### NOTE

See the current project report for the number and location of ballasting.

# 6

Insert the modules vertically into the Pivot Single E and screw them in on the reverse side.

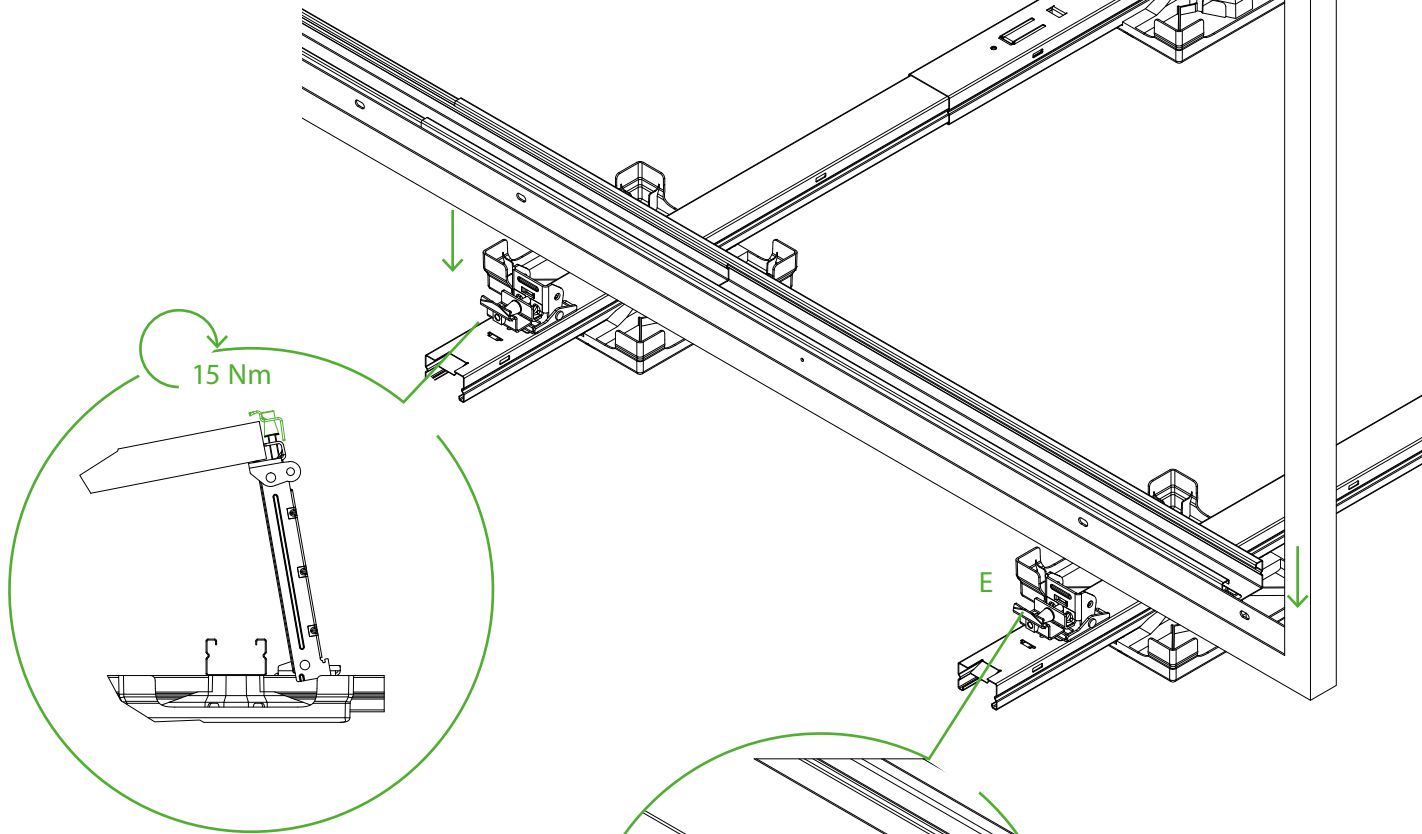

Place the Pivot Single E in a vertical position and insert the module into the clamps from above. Then screw on from the rear side, checking that it is firmly in place and in the correct position.

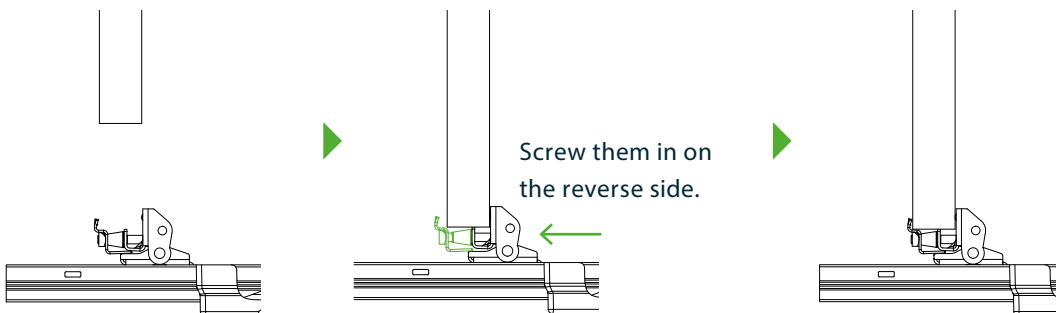
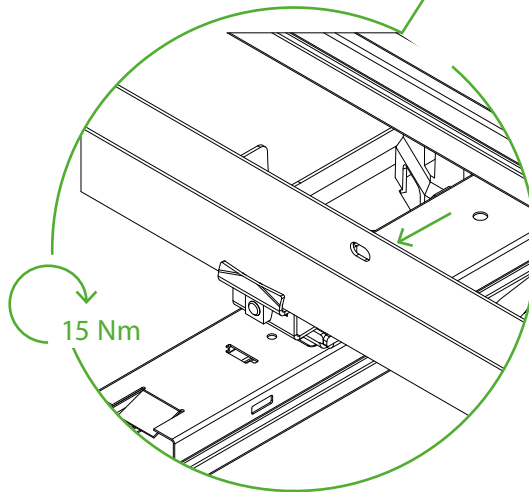

# 7

Fold down attached modules, insert into Summit Single D clamps and screw into place.

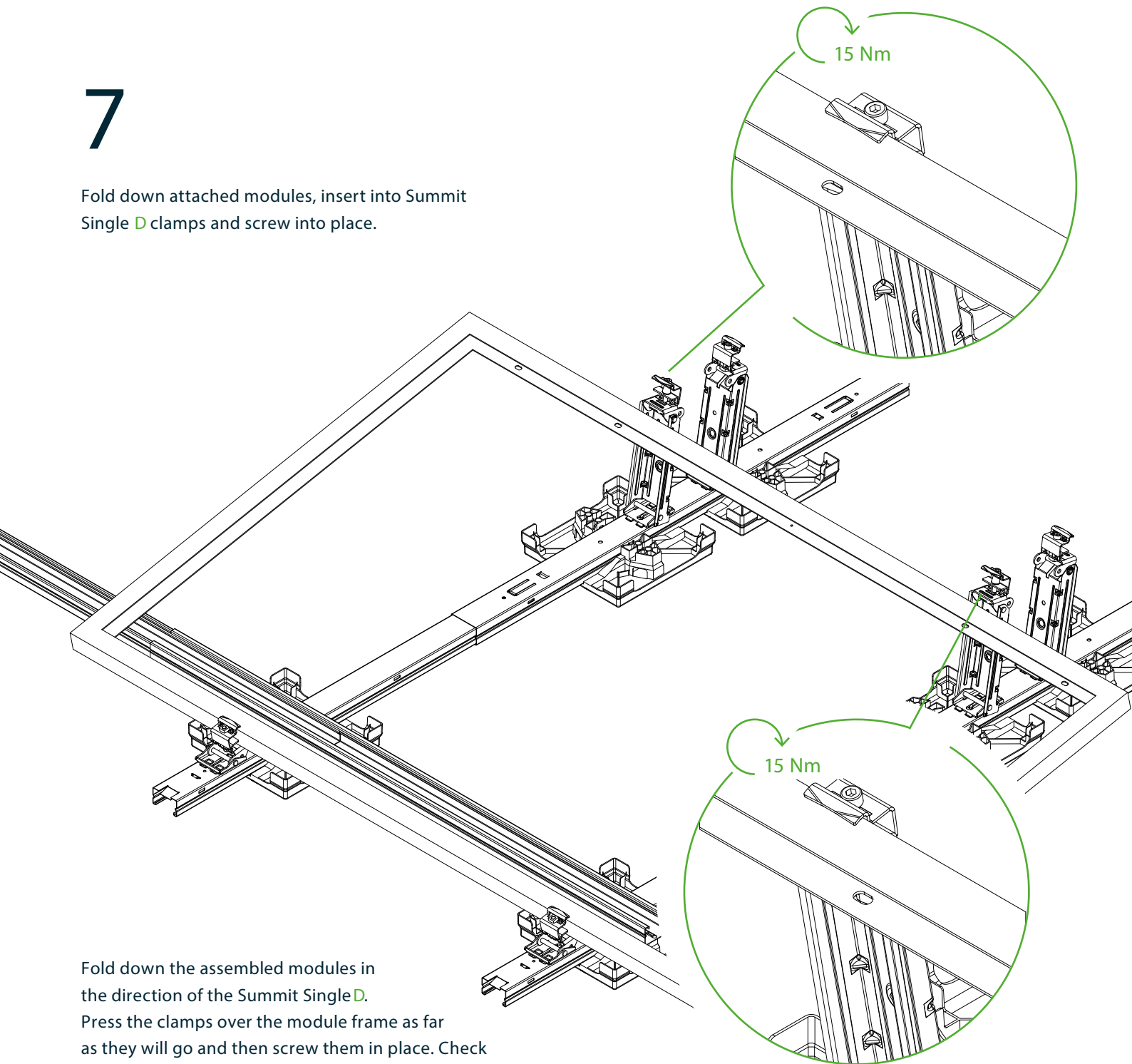

Fold down the assembled modules in the direction of the Summit Single D. Press the clamps over the module frame as far as they will go and then screw them in place. Check that it is correctly positioned and firmly in place.

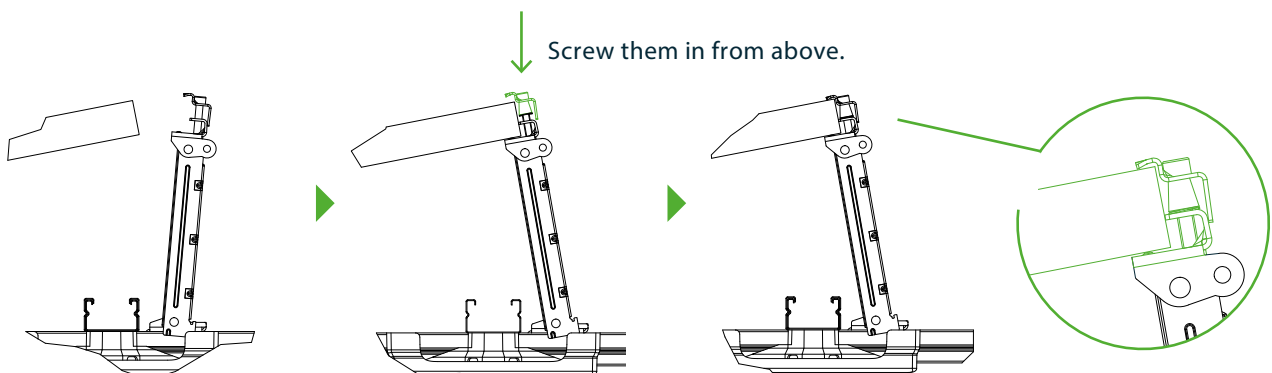



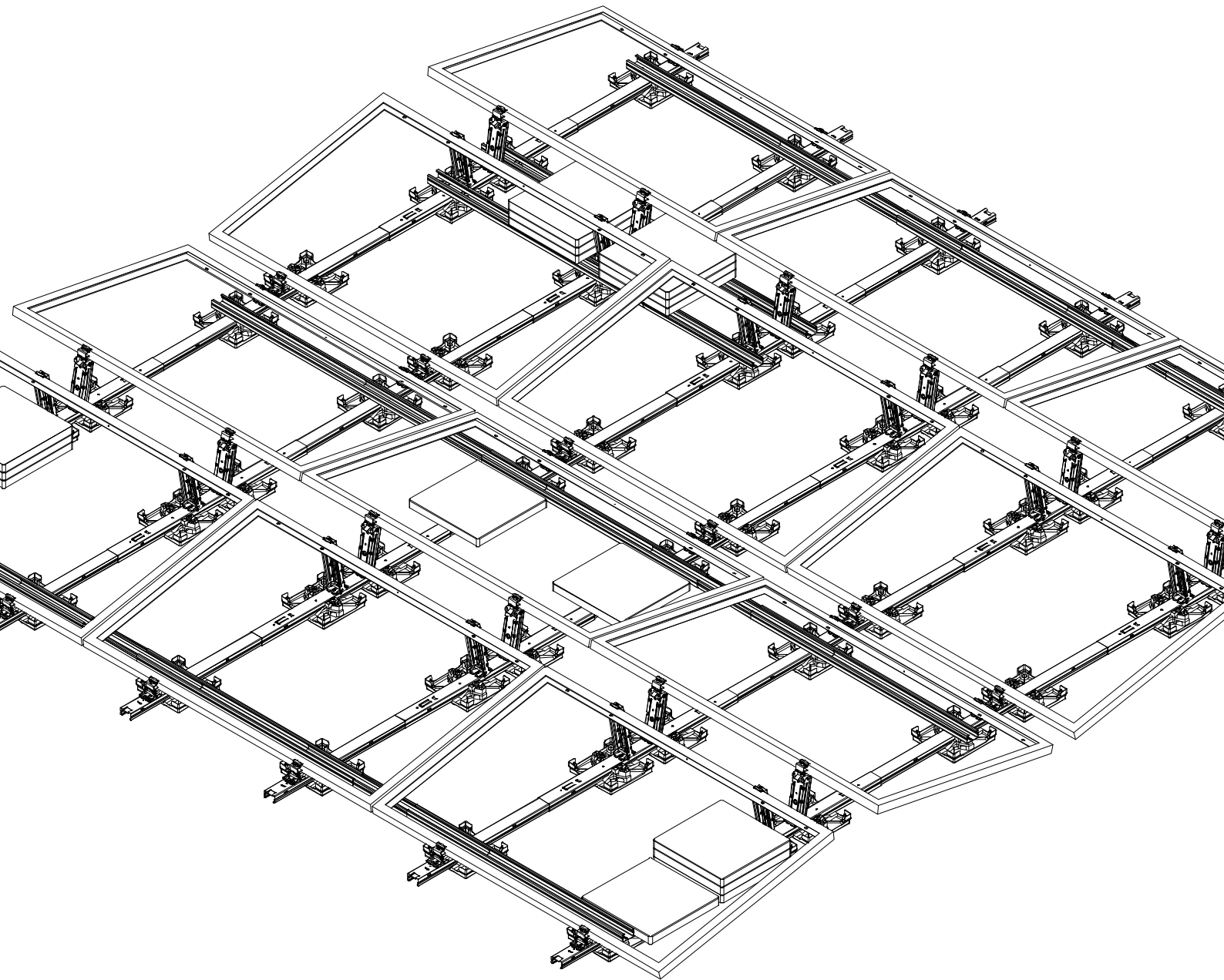

DONE WITH  
THE BASIC SYSTEM!

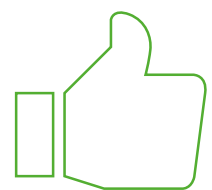



Attention! Some components are available in different lengths and versions.  
The exact item details can be found in the project documents.

# Optional component types

## 1 EasyPlate Gravel

PE-HD



## 5 Stud Link

1.0529 - S350 GD ZM310

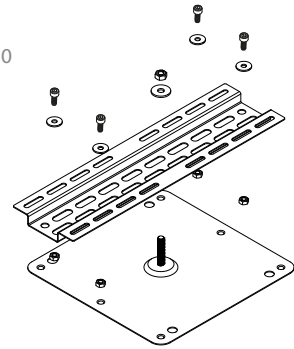

## 2 Swift Shield Link

1.0529 - S350 GD ZM310

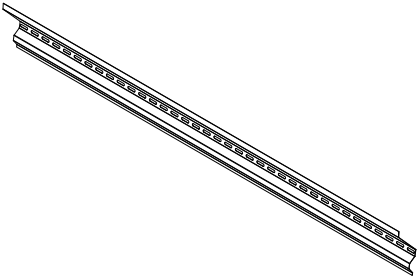

## 6 Row Ridge

1.0529 - S350 GD ZM310

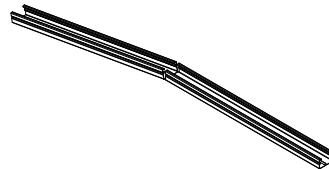

## 3 Swift Shield

1.0529 - S350 GD ZM310

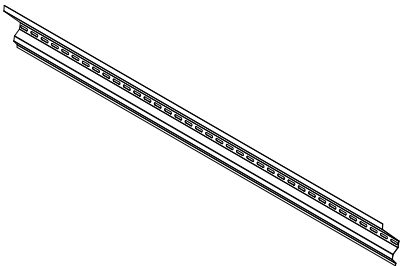

## 7 Swift Ridge

1.0529 - S350 GD ZM310

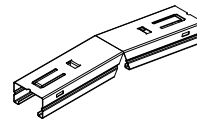

## 4 Swift Shield Bracket

1.0531 - S550 GD ZM310



## 8 Swift Edge

1.0529 - S350 GD ZM310

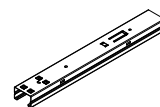

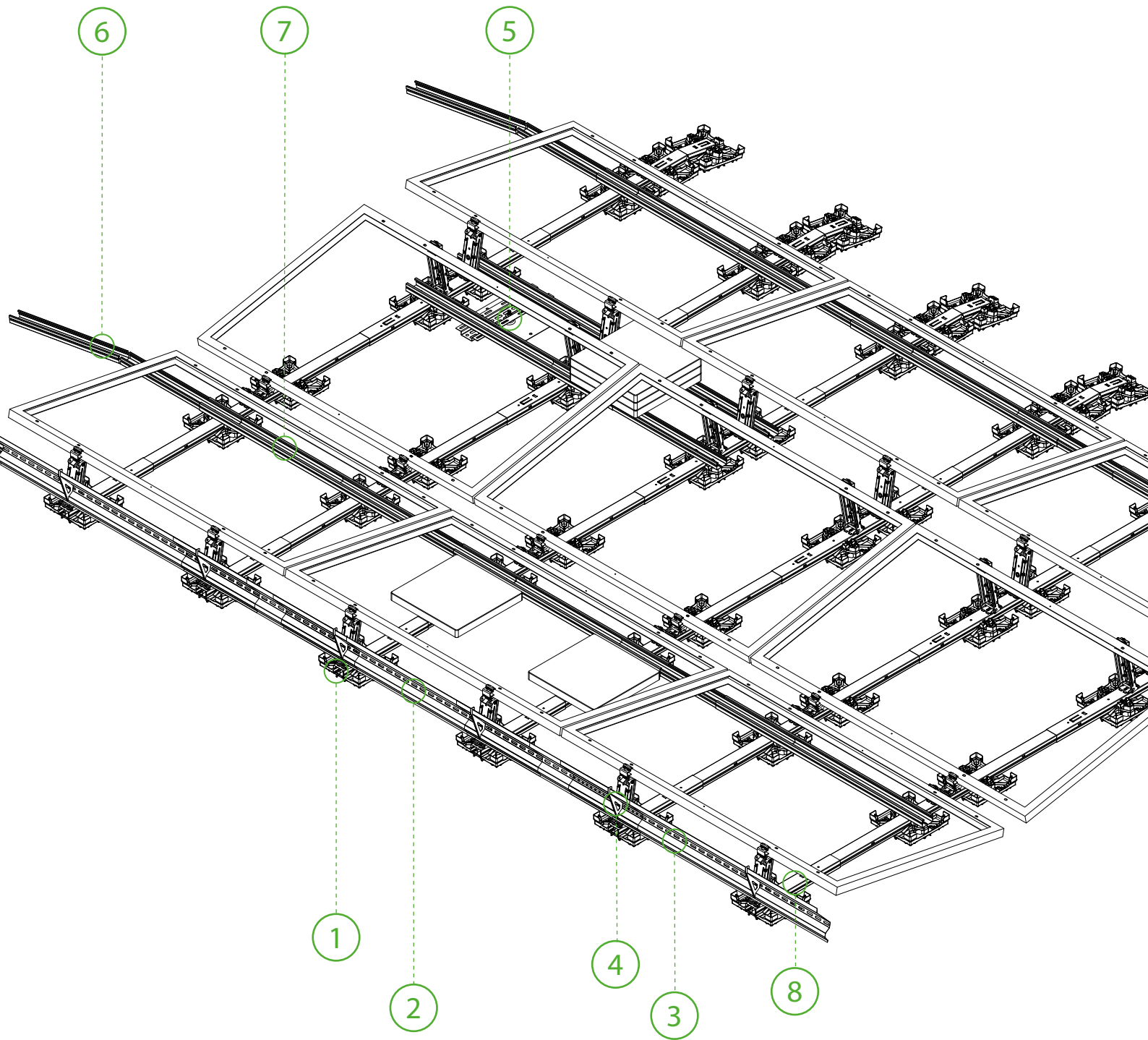

1 EasyPlate Gravel

2 Swift Shield Link

3 Swift Shield

4 Swift Shield Bracket

5 Stud Link

6 Row Ridge

7 Swift Ridge

8 Swift Edge



# Installation of special components

Optional installation steps:

- |   |                                  |   |             |
|---|----------------------------------|---|-------------|
| 1 | EasyPlate Gravel                 | 5 | Row Ridge   |
| 2 | Swift Shield Link & Swift Shield | 6 | Swift Ridge |
| 3 | Swift Shield Bracket             | 7 | Swift Edge  |
| 4 | Stud Link                        |   |             |

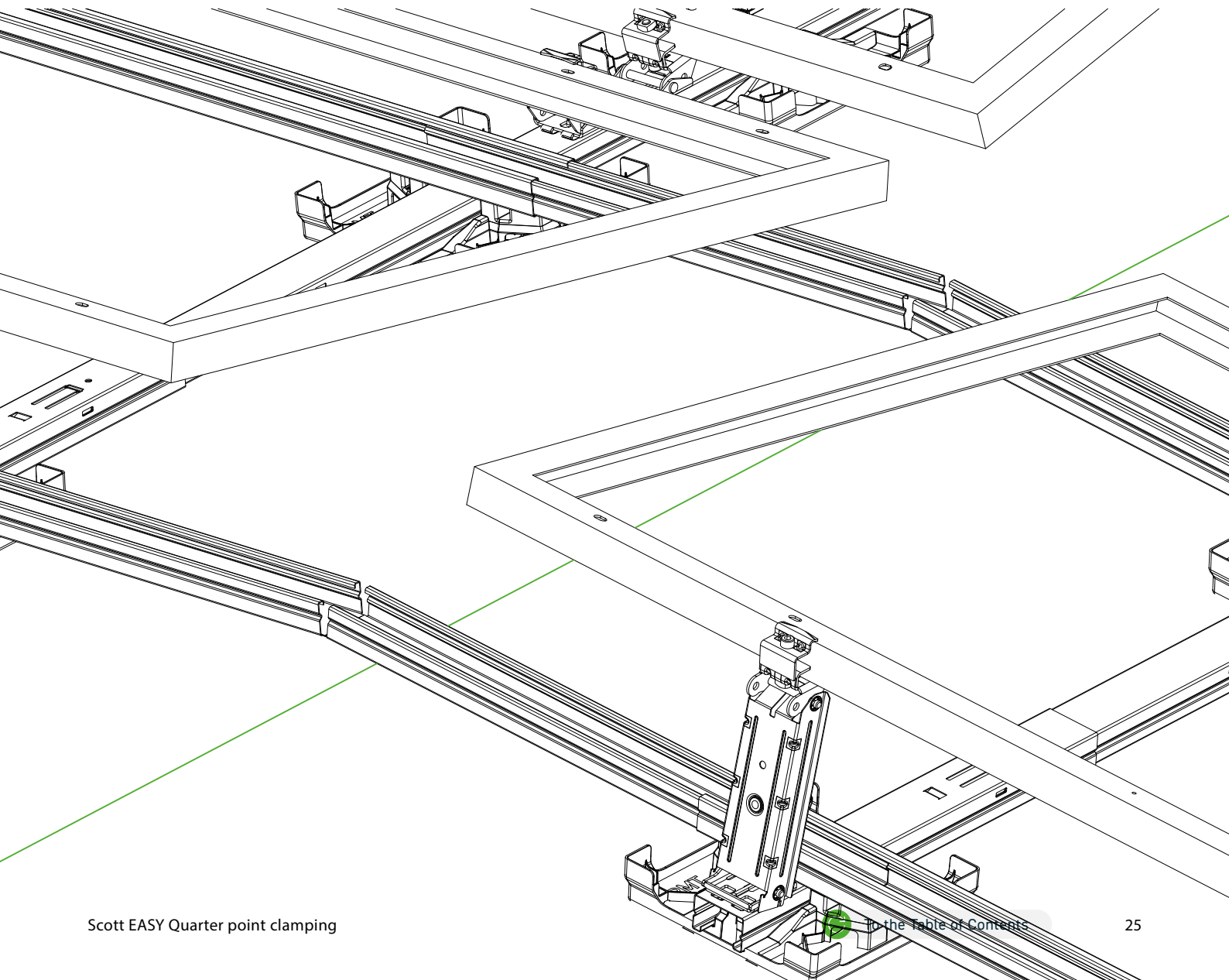

# 1

## OPTIONAL INSTALLATION STEP **EASYPLATE GRAVEL**

### Component EasyPlate Gravel

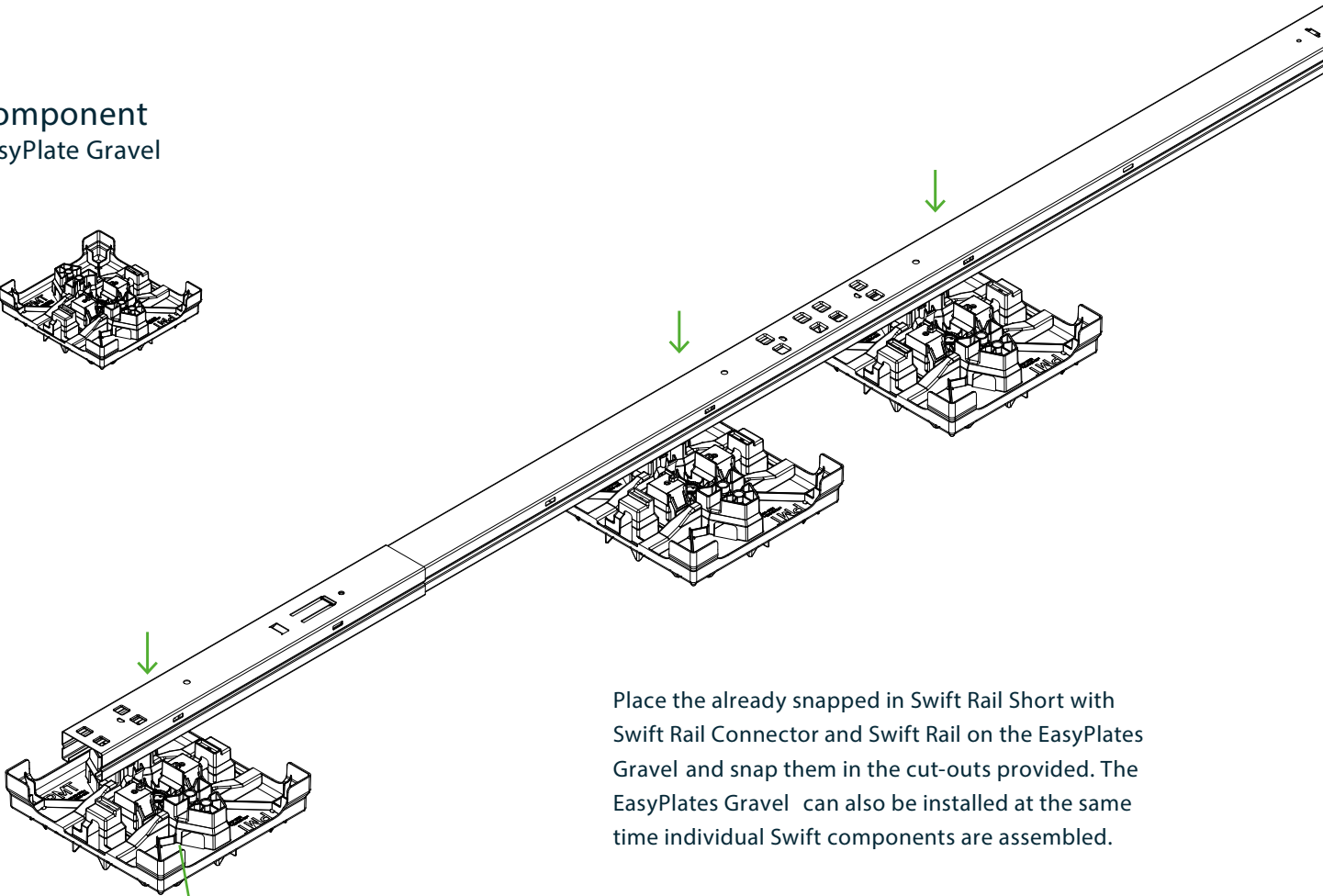
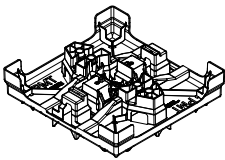

Place the already snapped in Swift Rail Short with Swift Rail Connector and Swift Rail on the EasyPlates Gravel and snap them in the cut-outs provided. The EasyPlates Gravel can also be installed at the same time individual Swift components are assembled.



**Attention!**  
Consult the current project report for the exact installation of the EasyPlates Gravel.

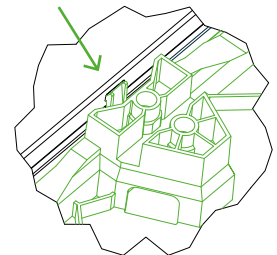
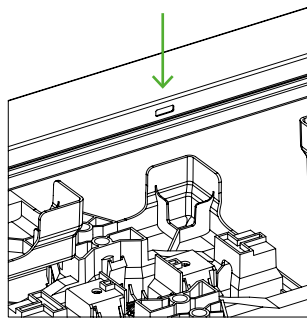
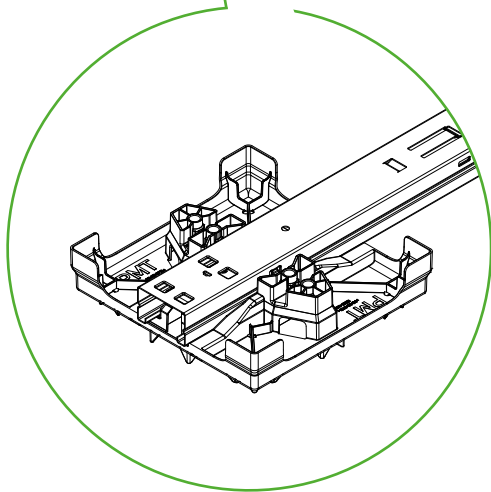

# 2

## OPTIONAL INSTALLATION STEP **SWIFT SHIELD LINK & SWIFT SHIELD**

Component  
Swift Shield Link

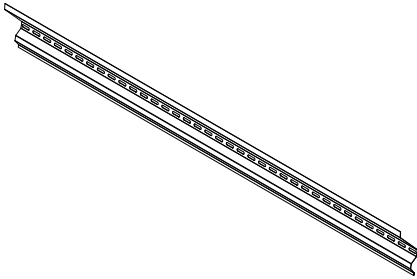

Swift Shield

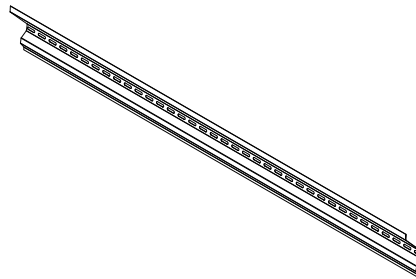

### Attention!

Ensure that the hole on the Summit Single is not covered by Swift Shield Link or Swift Shield.

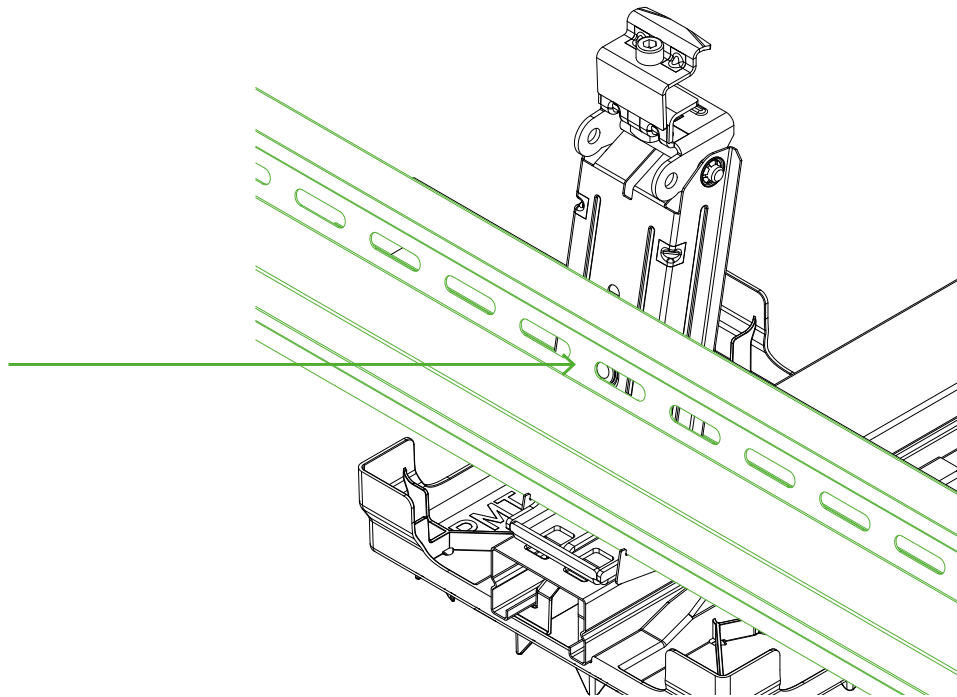

Place Swift Shield or Swift Shield Link on the back of the Summit Single and slide it down into the cut-out provided.

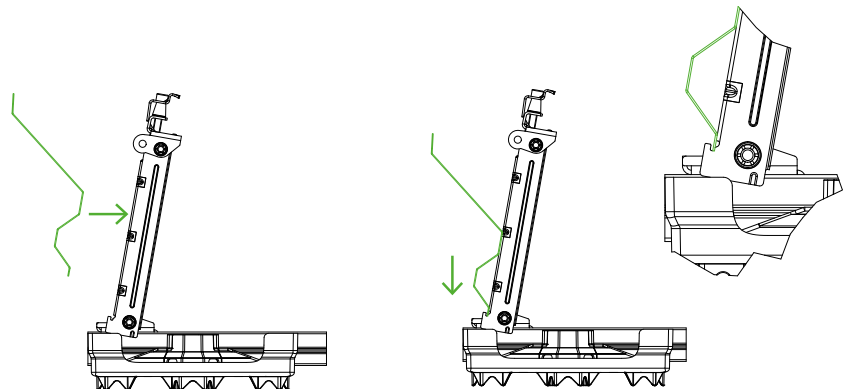

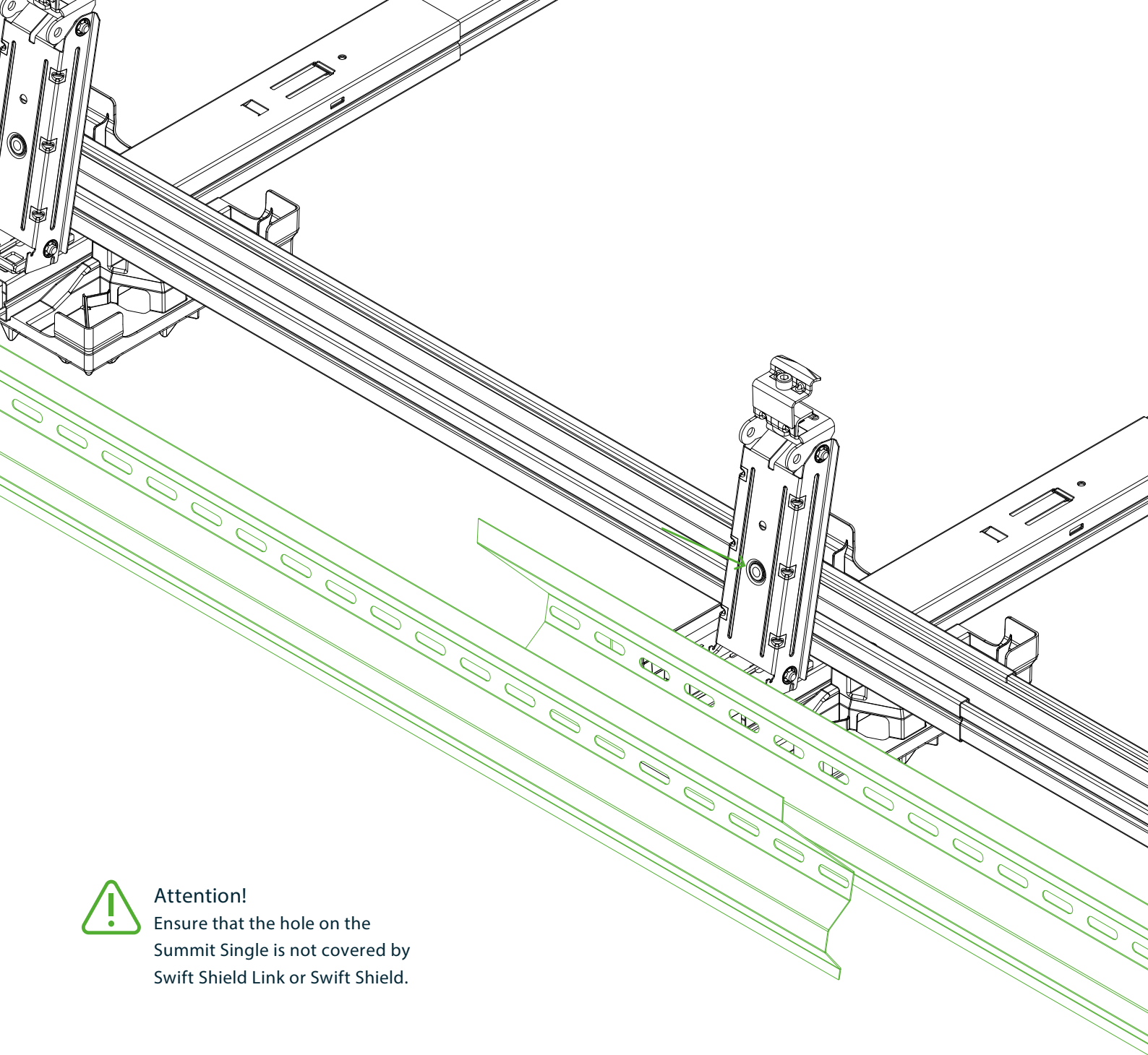

**Attention!**

Ensure that the hole on the Summit Single is not covered by Swift Shield Link or Swift Shield.

The Swift Shield Link is mounted in the same way as the Swift Shield. Ensure that both components have sufficient overlap.

# 3

## OPTIONAL INSTALLATION STEP **SWIFT SHIELD BRACKET**

**Component**  
Swift Shield Bracket

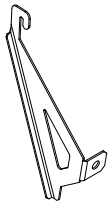

**Required tools**  
Torque wrench with attachment  
Hexagon socket SW6 mm

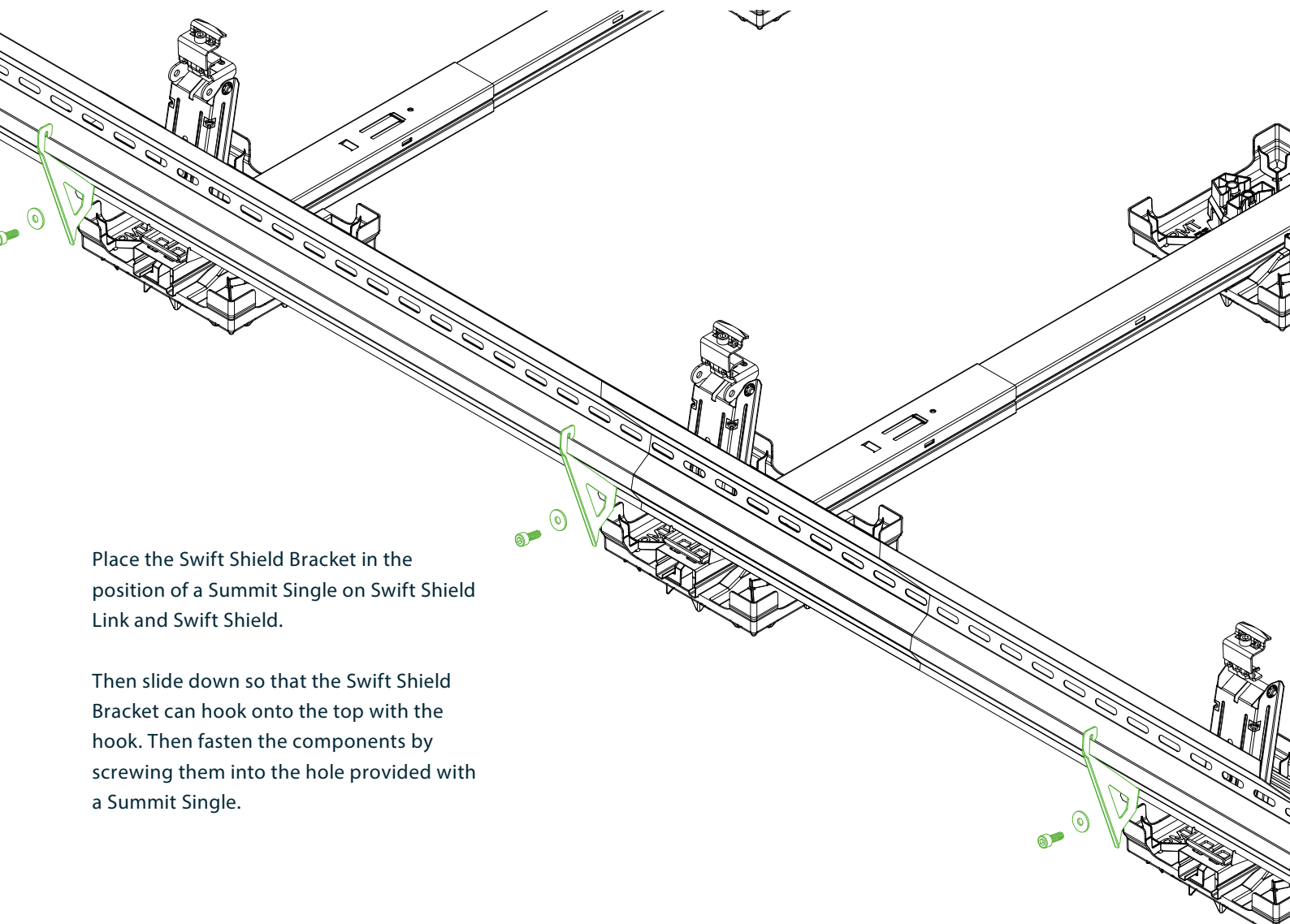
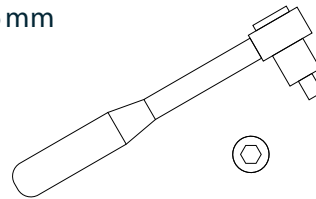

Place the Swift Shield Bracket in the position of a Summit Single on Swift Shield Link and Swift Shield.

Then slide down so that the Swift Shield Bracket can hook onto the top with the hook. Then fasten the components by screwing them into the hole provided with a Summit Single.

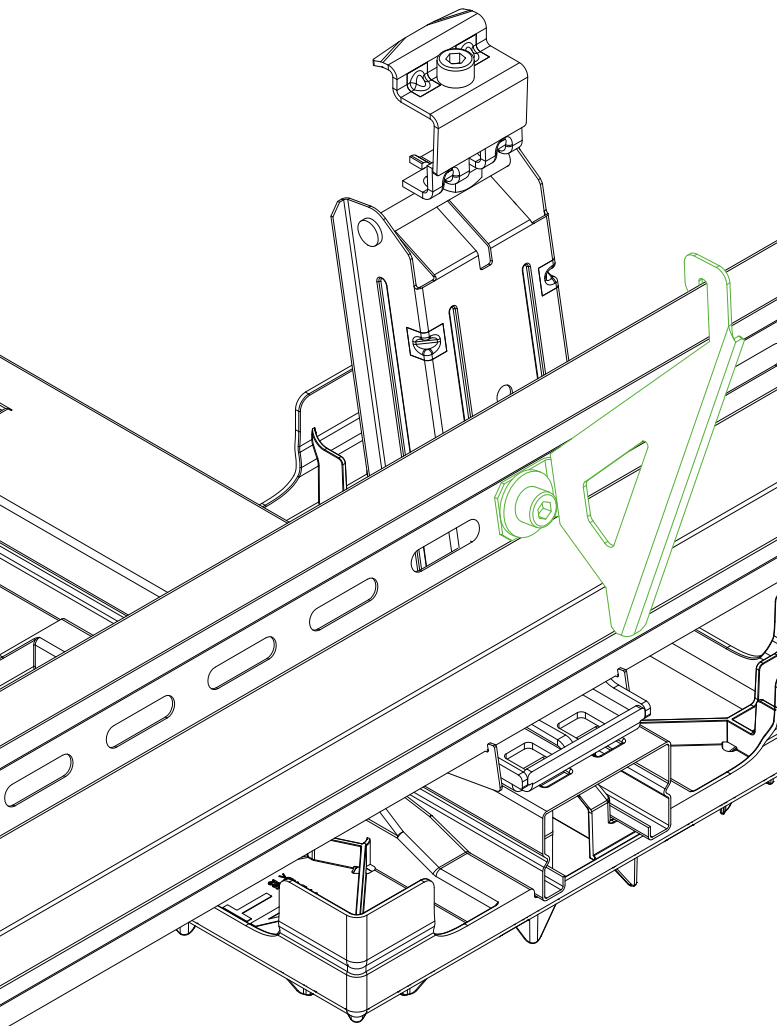
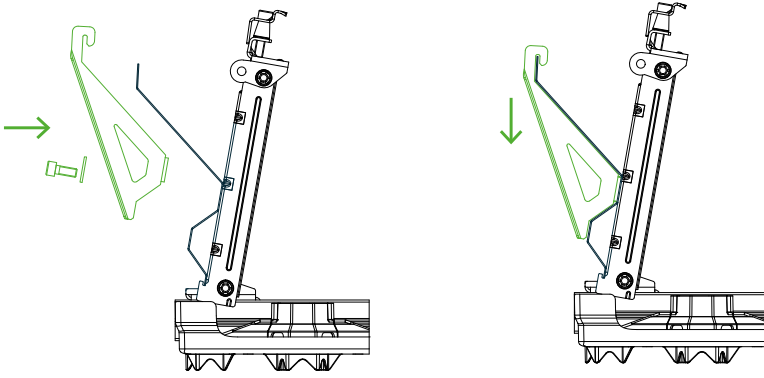

**Attention!**

Ensure that when attaching Swift Shield or Swift Shield Link, the hole on the Summit Single is not covered so that a Swift Shield Bracket can be attached there.

# 4

## OPTIONAL INSTALLATION STEP RIDGE CONNECTOR

Component  
Stud Link

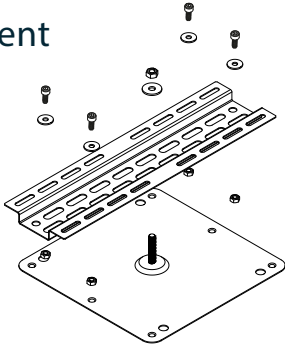

### Required tools

Torque wrench with  
attachment Hexagon socket SW6 mm  
and open-end wrench  
SW 16mm + SW13mm

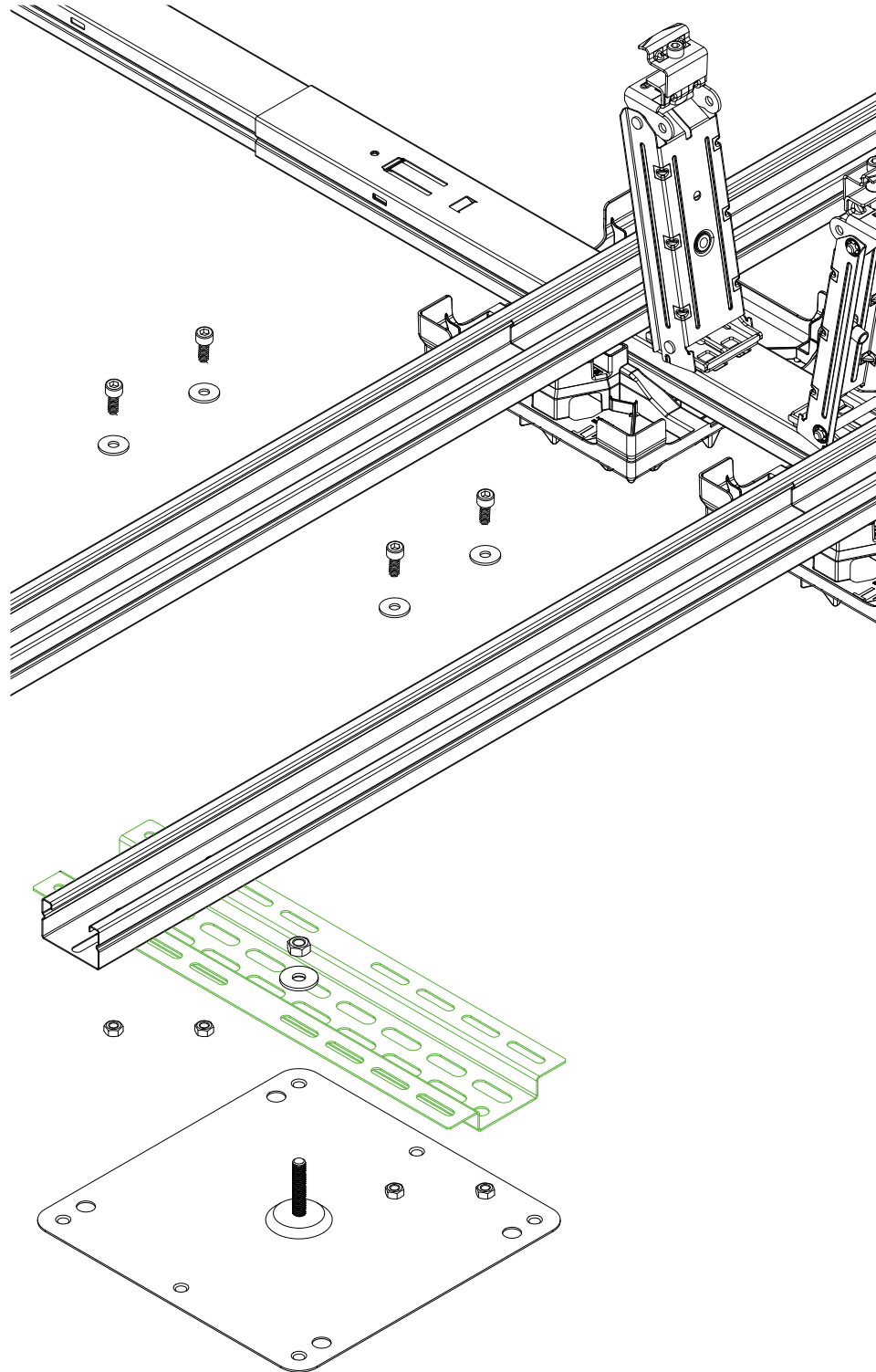
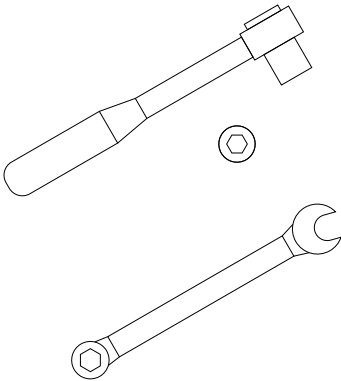



The Stud Link attachment points are located on the Row Connector or Row Link and should be fitted before the Stud Link is installed. The Stud Link connection should be fixed as close as possible to a rail.

The Stud Link is aligned centrally and pushed over the threaded bolt.

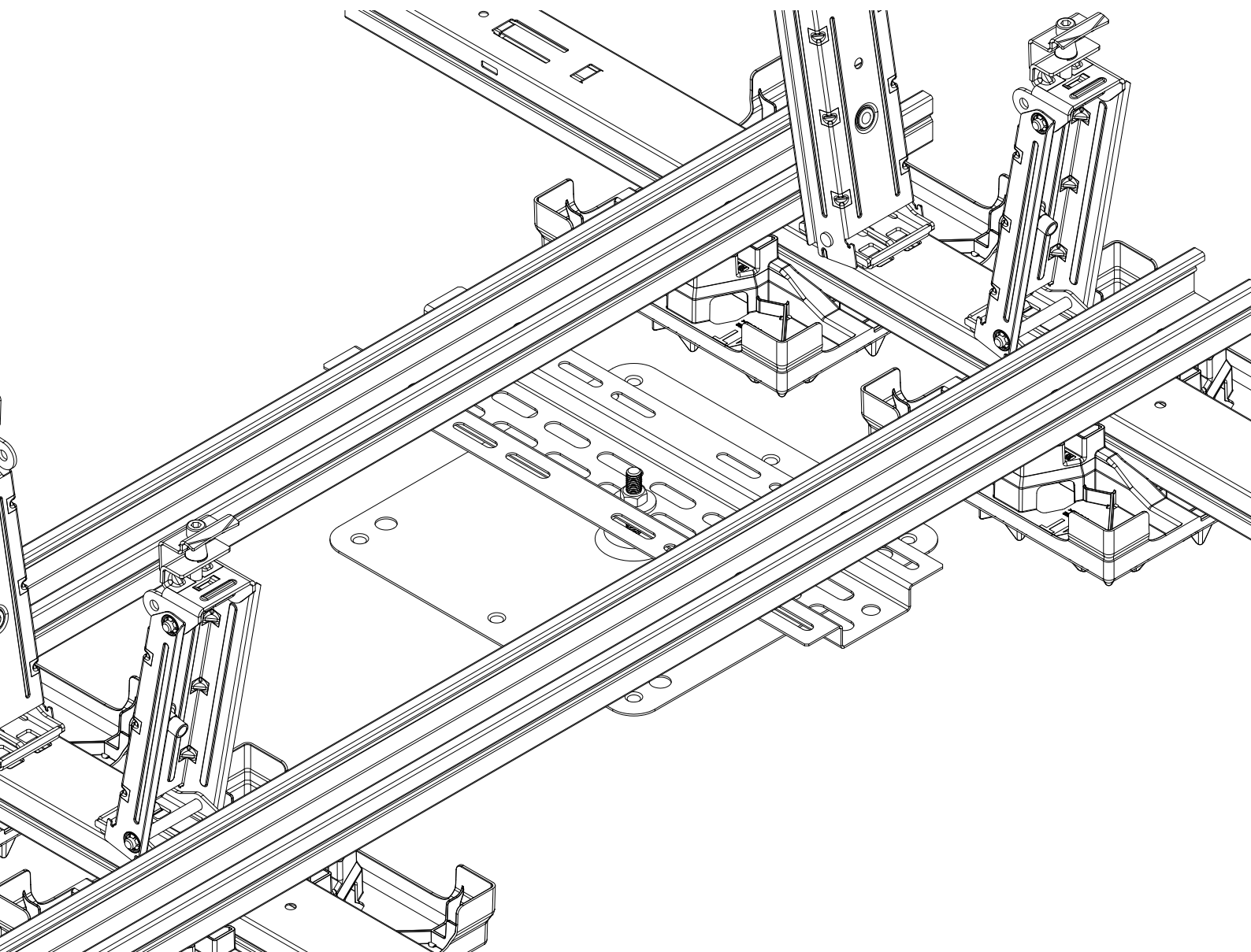



# 5

## OPTIONAL INSTALLATION STEP **ROW RIDGE**

Component  
Row Ridge

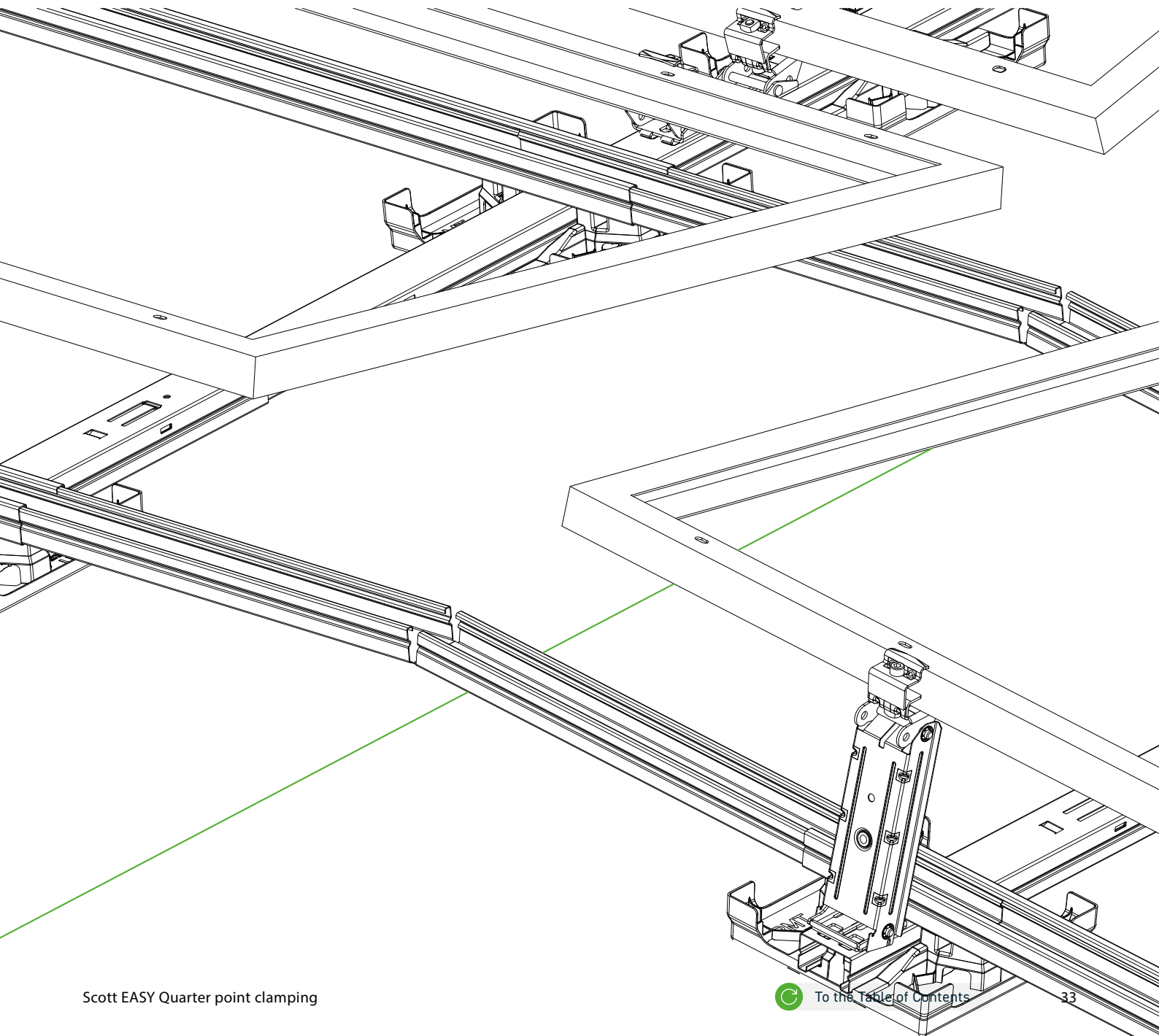
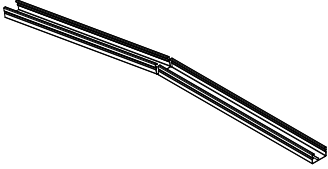

First, the ridge line is determined. Then the Swift Rail profiles are assembled (parallel to the ridge).

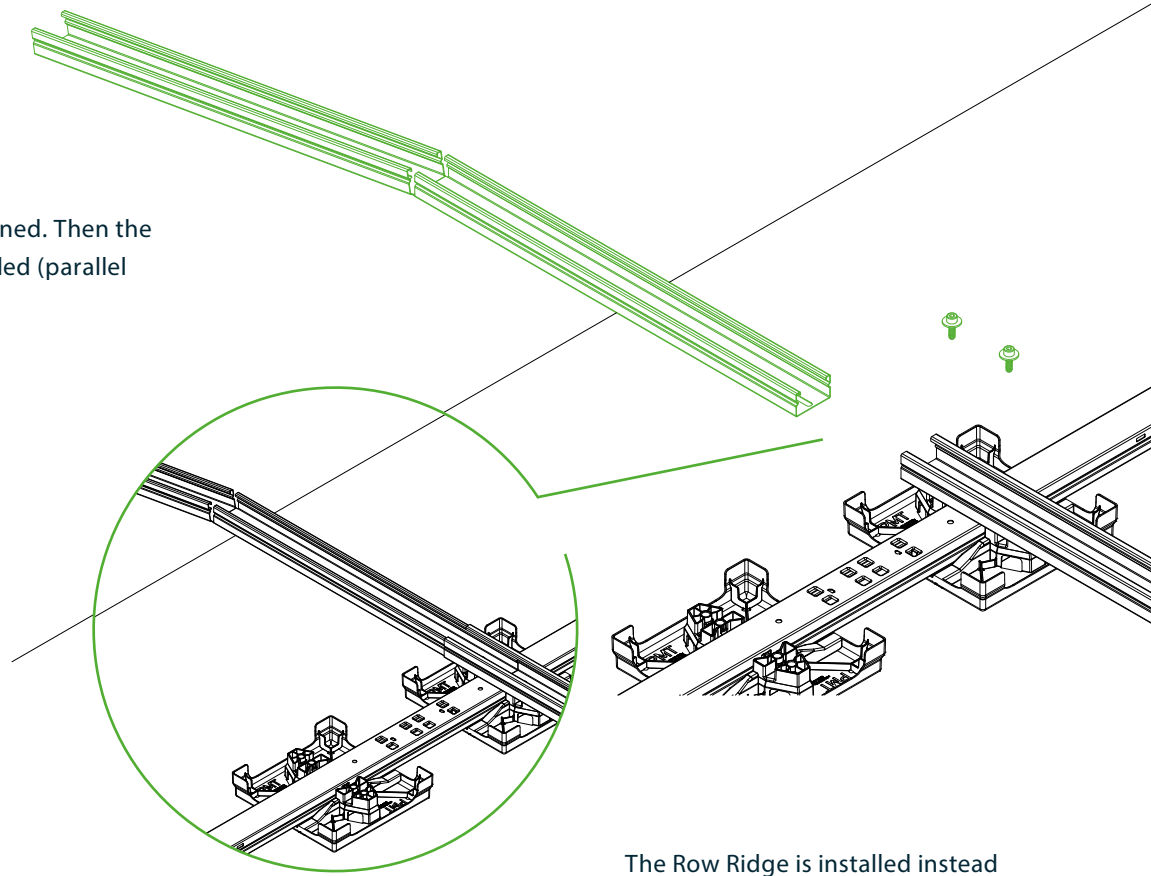

The Row Ridge is installed instead of a Row Connector or Row Link. The structure should be assembled evenly on both sides to prevent lopsided loading and thus slipping. Always refer to the current project documents for the location and position of the ridge connectors.

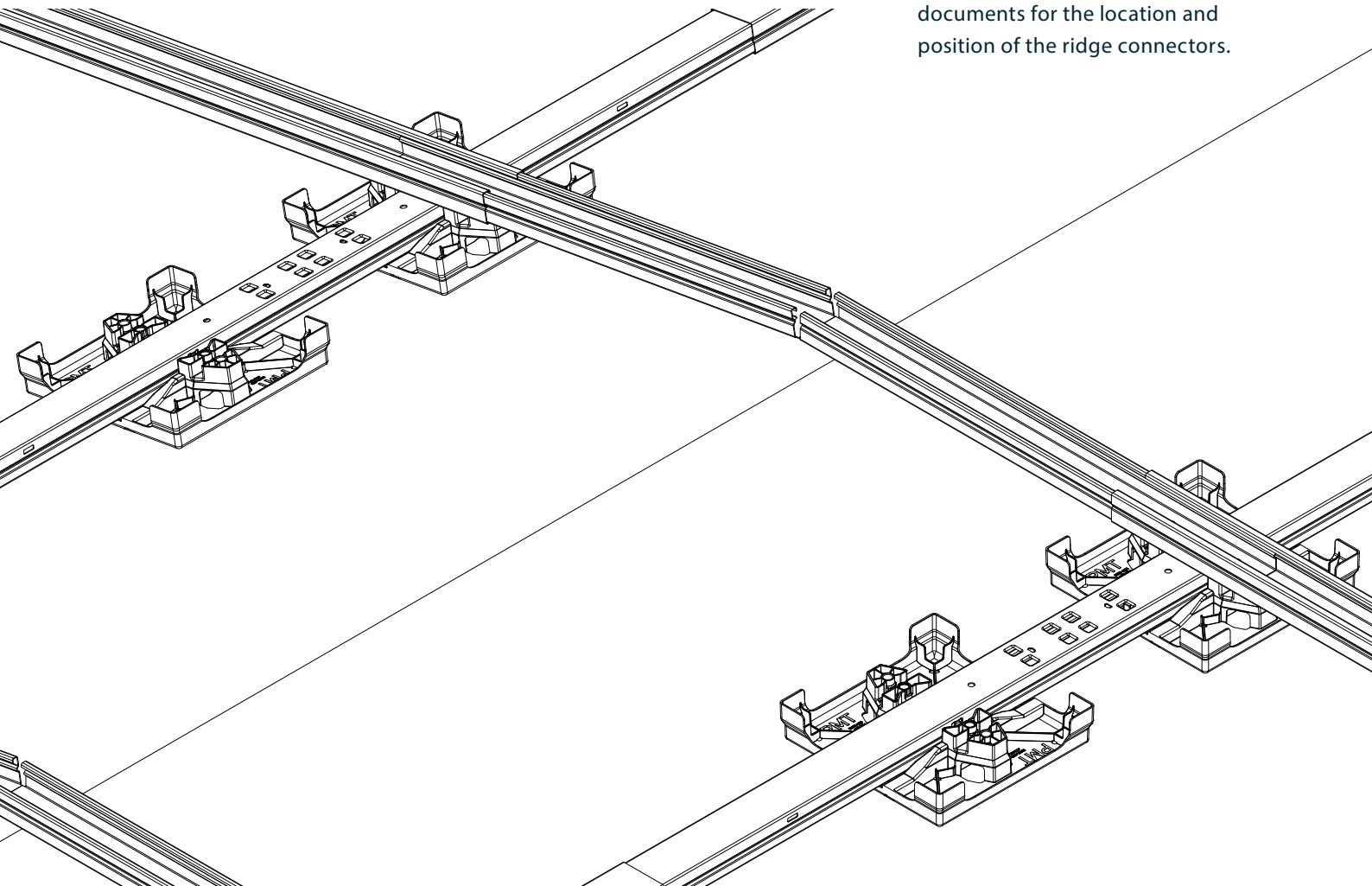

# 6

## OPTIONAL INSTALLATION STEP **SWIFT RIDGE**

### Component Swift Ridge

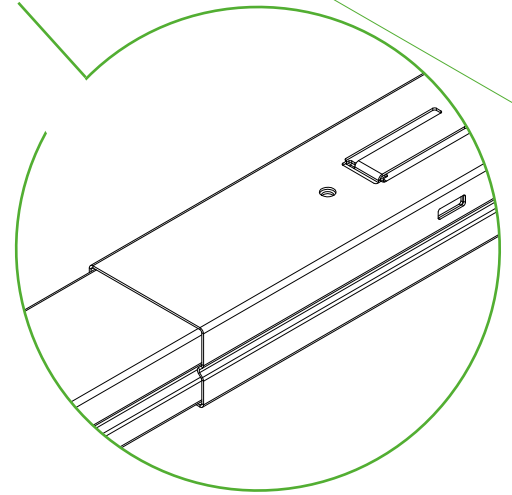
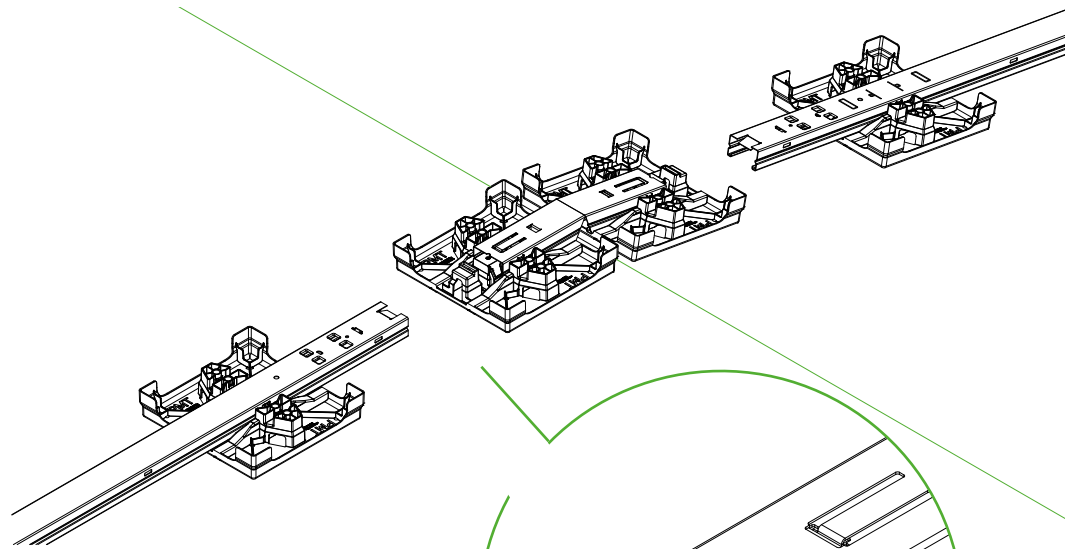
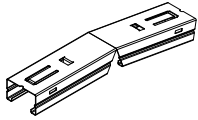

First, the ridge line is determined.

Then the Swift Rail profiles are assembled and the Swift Ridge is installed instead of the Swift Rail Short. The structure should be assembled evenly on both sides to prevent lopsided loading and thus slipping. Always refer to the current project documents for the location and position of the ridge connectors.

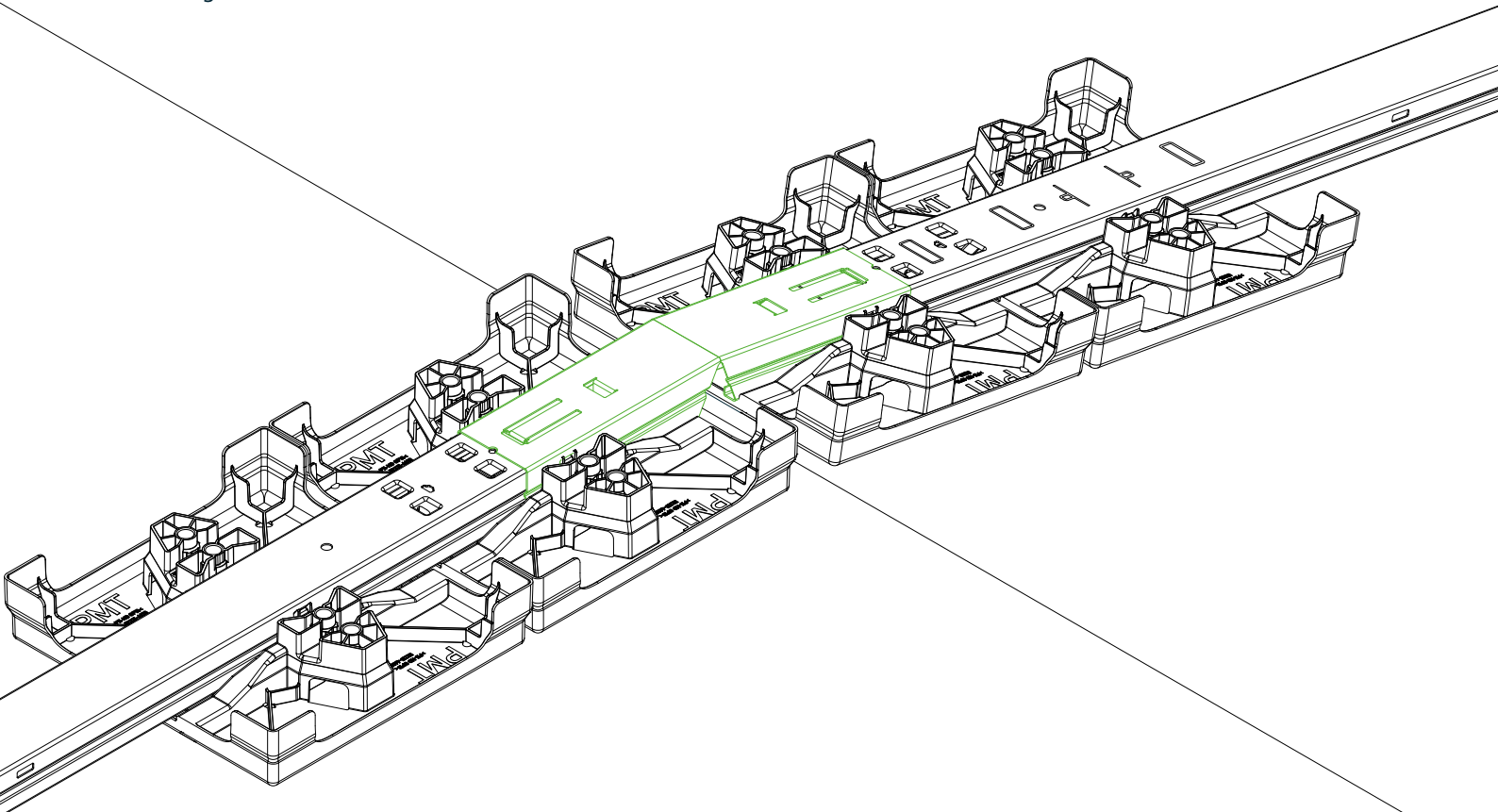

# 7

## OPTIONAL INSTALLATION STEP **SWIFT EDGE**

Component  
Swift Edge

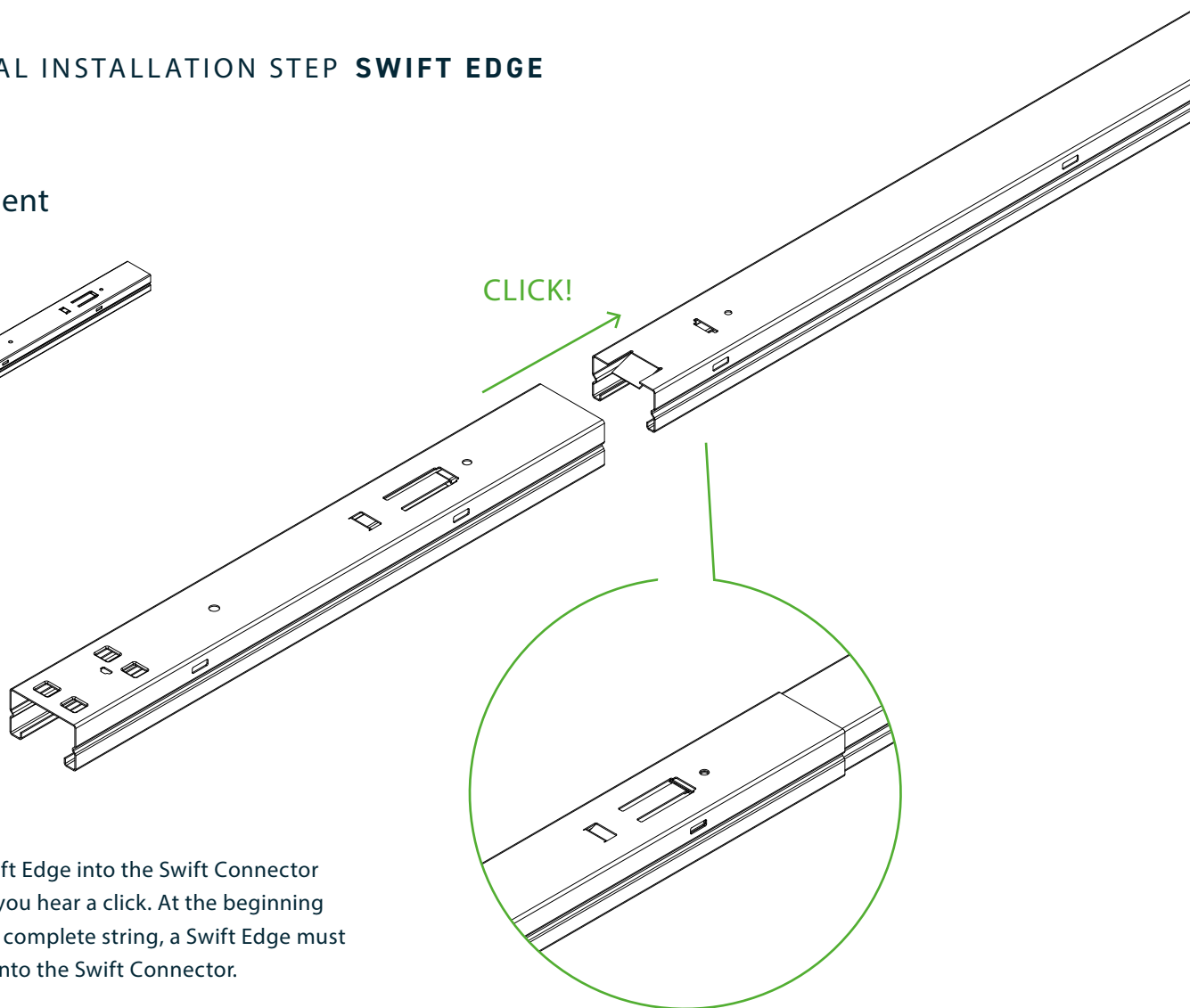
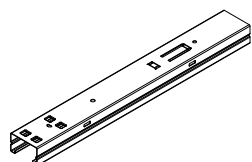

Slide the Swift Edge into the Swift Connector profile until you hear a click. At the beginning and end of a complete string, a Swift Edge must be pushed onto the Swift Connector.

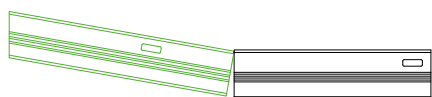

**Scott tip**  
Place the Swift Edge at a slight angle to the profile of the Swift Connector and push it in with a tilting movement.



**Attention!**  
Check the snap-lock joint for strength and to ensure it fits perfectly.

**CORRECT!**

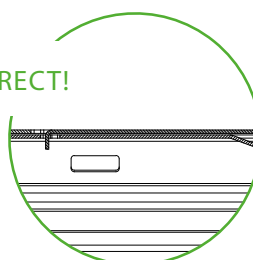

**WRONG!**

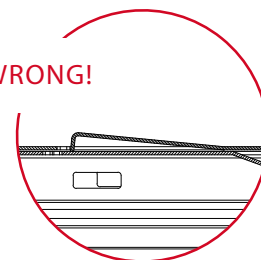

# Final examination

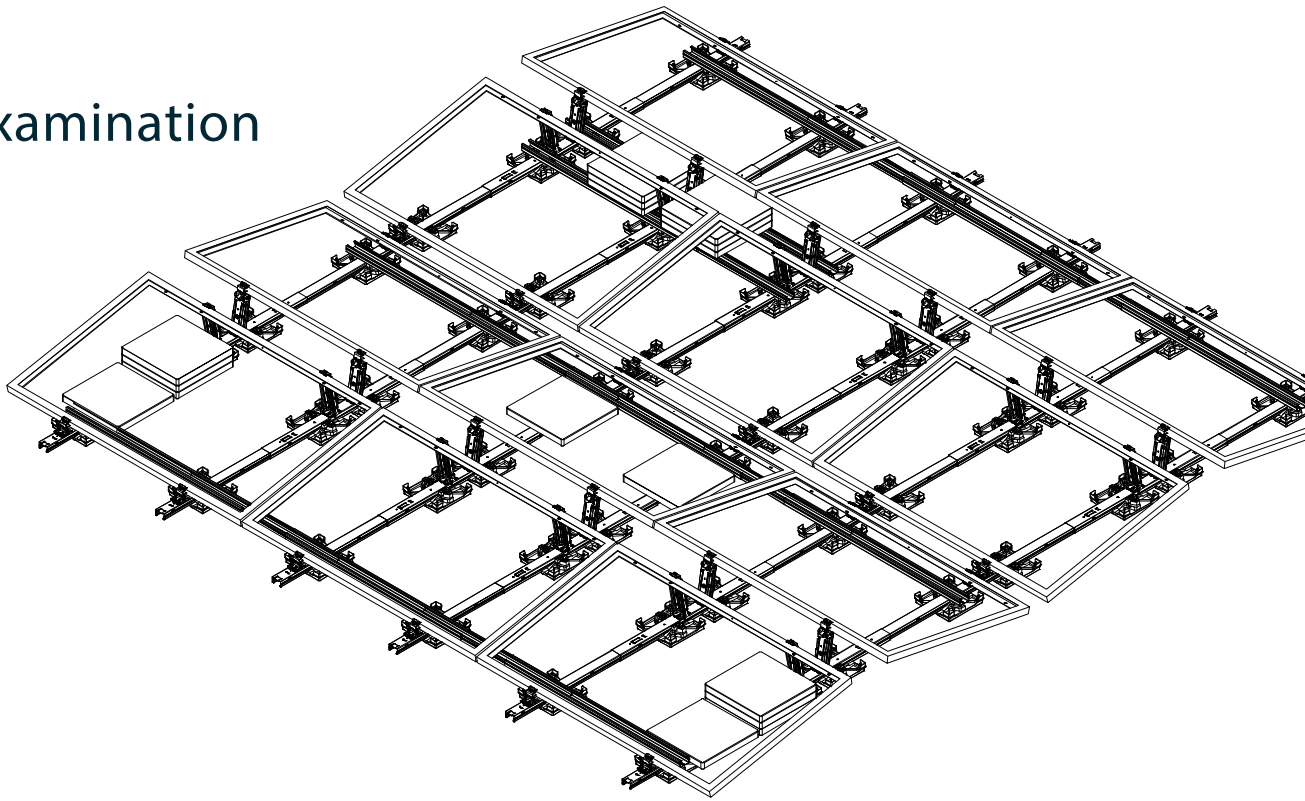

## Final examination

- Check whether the entire system and all components have been installed in accordance with the current project report.
- Check that all screws are inserted in the correct positions and tightened to the specified torque.
- Information on the tightening torque can be found in the installation instructions or on the packaging. Attention! This is important for safety reasons and can lead to considerable damage if not adhered to.
- Check that all ballasting has been done with the specified weights. This information can be found in the current project report. Make sure that the ballast elements are completely prevented from sliding down, tilting or rocking. Attention! This is important for safety reasons and can lead to considerable damage if not adhered to.
- Check that all click connections are properly engaged.

## Maintenance

- The upper and lower limits of the tightening torque of the screw connections must be checked regularly as part of the maintenance (maintenance interval at least once a year; observe the maintenance protocol).
- The recommendations on the maintenance routines of the EVO 2.1 system due to thermal expansion must be observed.

# Warranty and product liability

---

Please note that a product warranty is only granted in accordance with our warranty conditions if all safety and system instructions have been complied with and the system has been installed properly. You can access the warranty conditions at [scott.no/download](https://scott.no/download) .

---





We are happy to advise you!



KRISTOFFER STEINE

NEXT LEVEL  
MOUNTING

Founder  
Head of Sales  
Scott Norge AS

-  [steine@scott.no](mailto:steine@scott.no)
-  +47 92 43 09 07
-  Espehaugen 32, 5258 Blomsterdalen
-  [www.scott.no](http://www.scott.no)



GISLE HAUGLAND

NEXT LEVEL  
MOUNTING

Founder  
CEO  
Scott Norge AS

-  [gisle@scott.no](mailto:gisle@scott.no)
-  +47 99 35 35 14
-  Espehaugen 32, 5258 Blomsterdalen
-  [www.scott.no](http://www.scott.no)

